

Dimension

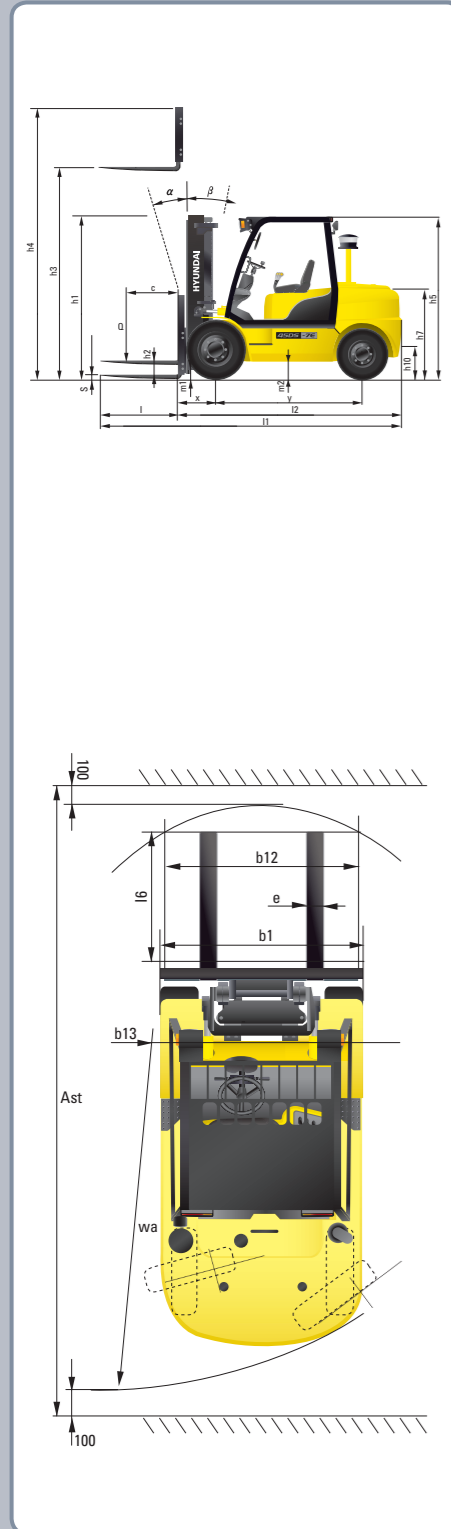

Specification

Identification					
1.1	Manufacturer	Hyundai	Hyundai	Hyundai	Hyundai
1.2	Manufacturer's type designation	35DS-7E	40DS-7E	45DS-7E	50DA-7E
1.3	Drive: electric (battery or mains), diesel, petrol, fuel gas, manual	DIESEL	DIESEL	DIESEL	DIESEL
1.4	Type of operation: hand, pedestrian, standing, seated, order-picker	seated	seated	seated	seated
1.5	Load capacity / rated load	kg 3,500	4,000	4,500	5,000
1.6	Load center distance	c(mm) 600	600	600	600
1.8	Load distance, center of drive axle to fork	x(mm) 561	561	561	576
1.9	Wheelbase	y(mm) 2,000	2,000	2,000	2,000
Weights					
2.1	Service weight	kg 5,894	6,464	6,880	7,302
2.2	Axle loading, loaded front/rear	kg 8,371 / 1,024	9,291 / 1,173	10,088 / 1,292	10,928 / 1,373
2.3	Axle loading, unloaded front/rear	kg 2,841 / 3,054	2,971 / 3,493	2,978 / 3,902	2,988 / 4,313
Wheels, Chassis					
3.1	Tires: solid rubber, superelastic, pneumatic, polyurethane	pneumatic	pneumatic	pneumatic	pneumatic
3.2	Tires size, front(Φ x width)	8.25-15-14	7.50-16-12	7.50-16-12	7.50-16-12
3.3	Tires size, rear(Φ x width)	7.00-12-12	7.00-12-12	7.00-12-12	7.00-12-14
3.5	Wheels, number front x rear (x=driven wheels)	2 x 2	4 x 2	4 x 2	4 x 2
3.6	Track width, front	mm 1,162	1,312	1,312	1,312
3.7	Track width, rear	mm 1,140	1,140	1,140	1,140
Basic Dimensions					
4.1	Mast / fork carriage tilt forward / backward (α / β)	degrees 8 / 10	8 / 10	8 / 10	8 / 10
4.2	Lowered mast height	h1 (mm) 2,235	2,220	2,220	2,220
4.3	Free lift	h2 (mm) 120	120	120	120
4.4	Lift height	h3 (mm) 3,000	3,000	3,000	2,900
4.5	Extended mast height	h4 (mm) 4,224	4,224	4,235	4,135
4.7	Overhead guard height (low opt/ std/ high opt)	h5 (mm) 2,200 / 2,240 / 2,340	2,200 / 2,240 / 2,340	2,200 / 2,240 / 2,340	2,200 / 2,240 / 2,340
4.8	Seat height / standing height	h7 (mm) 1,100	1,100	1,100	1,100
4.12	Coupling height	h10 (mm) 364	364	364	364
4.19	Overall length	l1 (mm) 4,140	4,195	4,405	4,450
4.20	Length to face of forks	l2 (mm) 3,070	3,125	3,185	3,250
4.21	Overall width	b1 (mm) 1,400	1,776	1,776	1,776
4.22	Fork dimensions(hook type)	s / e / l (mm) 50 x 122 x 1,070	50 x 150 x 1,070	50 x 150 x 1,220	60 x 150 x 1,200
4.23	Fork carriage ISO 2328, class / type A,B	III / A	III / A	IV / A	IV / A
4.24	Fork-carriage width	b3 (mm) 1,300	1,600	1,600	1,600
4.31	Ground clearance, loaded, under mast	m1 (mm) 170	155	155	155
4.32	Ground clearance, centre of wheelbase	m2 (mm) 215	200	200	200
4.33	Aisle width for pallets 1,000x1,200 crossways (LxW)	Ast (mm) 4,331	4,391	4,451	4,511
4.34	Aisle width for pallets 800x1,200 lengthways (WxL)	Ast (mm) 4,351	4,411	4,471	4,531
4.35	Turning radius	Wa (mm) 2,770	2,830	2,890	2,950
4.36	Smallest pivot point distance	b13 (mm) 996	996	996	996
Performance Data					
5.1	Travel speed, unloaded	km/h 27.1	26.1	26.1	26.0
5.2	Lift speed, loaded / unloaded	mm/s 520 / 580	520 / 580	520 / 580	450 / 470
5.3	Lowering speed, loaded / unloaded	mm/s 500 / 500	500 / 500	500 / 500	500 / 500
5.5	Drawbar pull, loaded	kg 3,773	3,859	3,842	3,867
5.7	Gradient performance, loaded / unloaded	% 38.7	34.8	31.8	30.8
5.9	Acceleration time, loaded / unloaded(10m)	-	-	-	-
5.10	Service brake	hydraulic	hydraulic	hydraulic	hydraulic
Engine					
6.1	Engine manufacturer / type	Mitsubishi S6S-T	Mitsubishi S6S-T	Mitsubishi S6S-T	Mitsubishi S6S-T
6.2	Engine power acc. to ISO 1585	kW 67.7	67.7	67.7	67.7
6.3	Rated speed	1/min 2,300	2,300	2,300	2,300
6.4	No. of cylinder / cubic capacity	cm ² 4,996	4,996	4,996	4,996
6.5	Fuel consumption acc. To VDI cycle	l / h 3.5	3.7	3.9	3.9
Other Details					
8.1	Type of drive control	Torque Converter 2/2	Torque Converter 2/2	Torque Converter 2/2	Torque Converter 2/2
8.2	Operating pressure (system / attach)	bar 210	210	210	210
8.3	Oil volume (hydraulic)	l 66	66	66	66
8.4	Noise (at driver's ear according to DIN 12053)	db(A) 82	82	82	82



■ Some of the photos may include optional equipment.

FORKLIFT TRUCKS Environmentally - Friendly

35/40/45DS/50DA-7E

■ Contact your Hyundai dealer for more information. The machine shown may vary according to International standards.

HYUNDAI
HEAVY INDUSTRIES CO.,LTD.

ООО "ЮЖУРАЛПОГРУЗЧИК"
454085, РФ, г. Челябинск, ул.
Танкистов, 179 корпус Б
Тел/факс: 8-351-270-20-55, 755-52-70
2702055@mail.ru
www.uralforklift.ru

HYUNDAI
HEAVY INDUSTRIES CO.,LTD.

We build a better future

35/40/45DS/50DA-7E

New criterion of Forklift Trucks

Hyundai introduces a new line of 7E-series diesel forklift trucks. Excellent power and performance make your business more profitable.



■ Some of the photos may include optional equipment.

High Power & Performance

Powerful Engine Mitsubishi S6S-T Engine

The six cylinders turbo-charged engine is built for power, reliability and economy. This engine meets EPA tier III and EU stage III emission regulation.

67.7kW/2,300rpm



State-of-the-art hydraulic system

The latest large-capacity hydraulic system reacts quickly during operation, and a low-noise control valve increases both efficiency and durability.

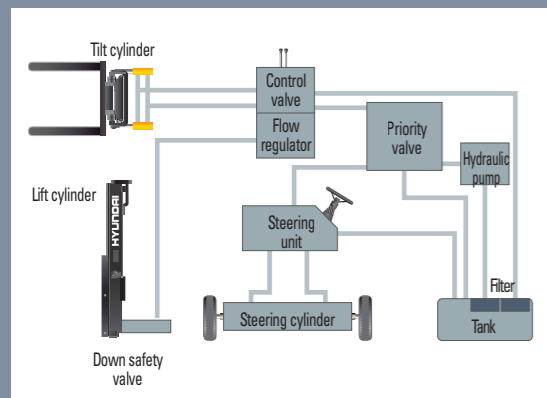

Some of the photos may include optional equipment.

The new master on the job-site!

Smooth running, efficient and ergonomically designed, 35/40/45DS/50DA-7E series are made to meet your needs.



Fast and stable performance

Being able to quickly raise and lower the mast, as well as tilt it forward and backward, providing the best operational conditions during unloading. When the truck is fully loaded, mast lowering speed is carefully controlled to ensure safety by the down control valve.

Faster travel speed & gradeability

The powerful high-output engine provides greater acceleration, better gradeability and faster travel speed on any tough terrain or slope.

Gradeability(Loaded)

35DS-7E	38.7%	45DS-7E	31.8%
40DS-7E	34.8%	50DA-7E	30.8%

Travel speed(Unloaded)

35DS-7E	27.1km/h	45DS-7E	26.1km/h
40DS-7E	26.1km/h	50DA-7E	26.0km/h

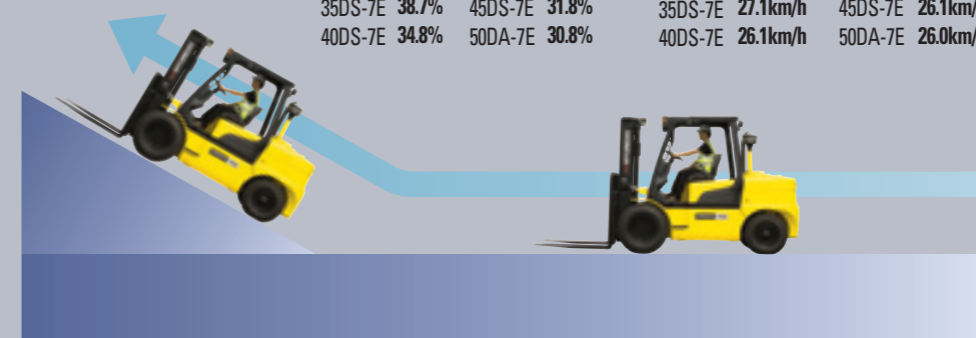

Increased mast tilting angle

The mast tilting angle of 8 degrees forward and 10 degrees backward, the operator can safely and rapidly perform loading and unloading jobs.



Wet disc brake system (Option)

The wet disc brake system is virtually maintenance free and is enclosed to protect from dust and water.



Fully hydrostatic power steering

A hydraulic steering system always guarantees smooth and flexible steering, preventing overrun and kick-back.

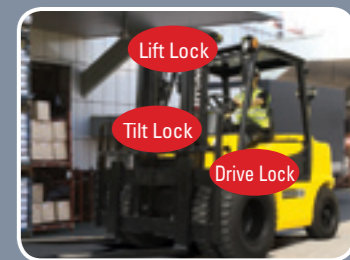

OPSS (Operator Presence Sensing System)

Control of mast tilting, lifting and lowering is not possible through operation of the appropriate control when the operator is not in the normal position. (Option)

Comfortable Operation



Adjustable steering wheel

Steering wheel with horn button can be adjusted by a lever on the right-hand side for the most comfortable operator position.



Easy and safe shift lever

A single lever on the left side of the steering column gives the operator fast and easy controls of the direction.



Multi-function switch lever

Multi-functional switch lever gives easy access to lights and horn.



Quick response of operating control levers

Only minimal operator's effort is required for precise, safe and productive control.



■ Some of the photos may include optional equipment.

Ergonomically designed with the operator in mind!

A design based on human engineering relieves fatigue and increases operator's efficiency.

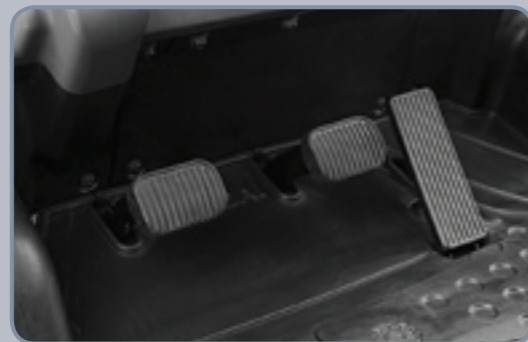

Ergonomically positioned pedals

Based on human engineering, the accelerator, brake and inching pedals are optimally positioned for convenience while operating the equipment.



Cup holder & console box

Additional storage spaces are located inside the operating space for operator's convenience.



New high visibility for safe operation

The operator is able to work with increased safety and accuracy due to a wider view mast.

Operator friendly gauges and water-resistant monitor panel



- | | |
|---|----------------------------|
| 1 Parking brake lamp | 8 Working light indicator |
| 2 Directional indicators | 9 Water separator lamp |
| 3 Fuel warning lamp | 10 Pre-heater indicator |
| 4 Engine oil warning lamp | 11 Water temperature gauge |
| 5 Transmission oil temperature warning lamp | 12 Fuel gauge |
| 6 Battery charging warning lamp | 13 Hour meter |
| 7 Air cleaner filter warning light | 14 Seat belt warning |
| | 15 OPS warning |

Easily adjustable suspension seat

An attractive and adjustable seat, based on a human engineering design, provides great comfort, safety and durability.



Full floating overhead guard mount

The anti-vibration rubber is installed between the guard and truck frame to reduce the source of vibration and noise while driving. This not only reduces operator's fatigue but also increases safety.



Endurance & Safety

Strong overhead guard

The safety overhead guard exceeds EEC and ANSI regulations and protects the operator during hazardous jobs.



Parking brake

Toggle type parking brake requires less efforts from the operator to set.



Highly durable transmission and drive axle

Powershift transmission provides fast travel speed and quiet travel under any heavy load condition, and boosts work efficiency.

Enhanced safety through high durability!

Safety and durability are priorities in the design of the equipment.



■ Some of the photos may include optional equipment.



Large footboard & hand grip

Wide "open" step offers convenience and safety when entering and exiting truck.

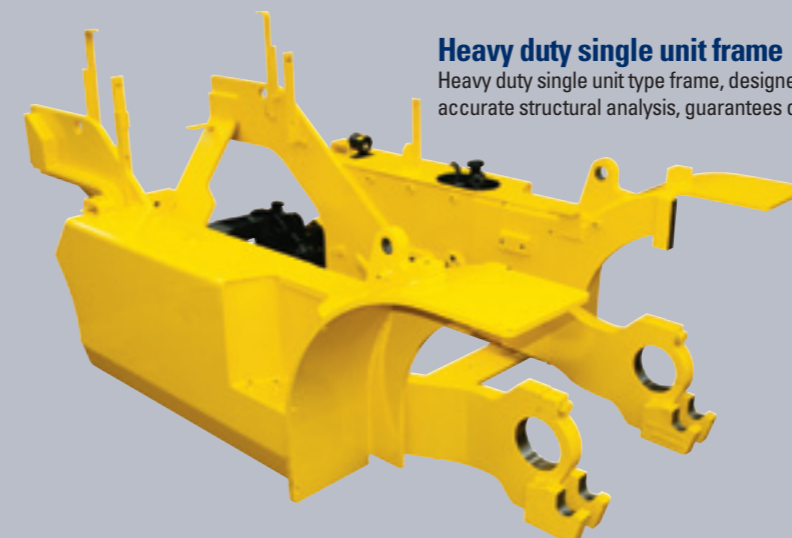

Heavy duty single unit frame

Heavy duty single unit type frame, designed on the basis of accurate structural analysis, guarantees durability and safety.



Easy access of electrical components

Various electric parts are centralized in dash board resulting in improvement in maintenance.



Expansion bellows

The expansion bellows absorbs vibration and reduces noise generated from the exhaust gas system and also extends the life cycle of exhaust gas system.



Bright, protected headlights

Bright, protected headlights is positioned for exceptional visibility.

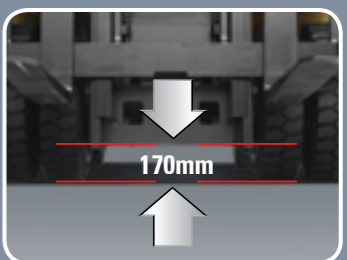

Ground clearance

The engine and transmission are assembled horizontally and positioned high in the frame to protect expansive components during operation on rugged surface.

Centralized design for easy service!

An ideal arrangement of component parts ensures easy accesses and conveniences for the maintenance.



Electrically monitored air filter

Air cleaner sensor alerts the operator of a restricted air filter and allows replacement before damage.



Easy maintenance oil check

The T/M oil level can be checked easily without any disassembly.



Brake fluid reservoir

Highly visible, easily accessible reservoir makes for quicker daily inspections.



An accessible, compact fuse box for easy inspection



Key-locking fuel cap with air vent

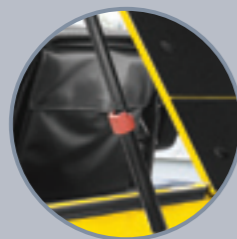

Automatic self locking gas spring

Engine compartment hood is held safely open by a self locking gas spring.



Easy change air cleaner

The air filter is readily accessible for cleaning or replacement. (7inch Cyclone Type)



■ Some of the photos may include optional equipment.



Large open engine hood

Highly accessible engine compartment assures fast and efficient maintenance.



Quick and easy engine oil check



Easy-to-access reservoir tank



Double battery installation

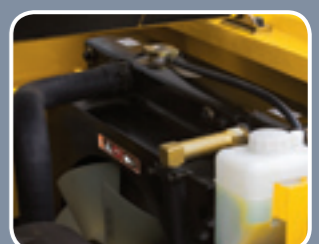

Easy-to-change radiator



Mechanic friendly fuel filter replacement

Specification

Mast Specification (35/40/45DS-7E)

Mast Type	Maximum Fork Height (mm)	Overall Height (Lowered) (mm)		Free Lift Height (mm)		Tilt Angle (deg)		Load Capacity without side shift at 600mm LC (kg)					Load Capacity with side shift at 600mmLC (kg)					Truck Weight (Unloaded) (kg)							
		Single Tire	Double Tire	With Backrest	Without Backrest	Fwd	Bwd	Single Tire		Double Tire			Single Tire		Double Tire			Single Tire	Double Tire						
		35/40/45DS-7E	35/40/45DS-7E	35/40/45DS-7E	35/40/45DS-7E			35DS-7E	40DS-7E	45DS-7E	35DS-7E	40DS-7E	45DS-7E	35DS-7E	40DS-7E	45DS-7E	35DS-7E			40DS-7E	45DS-7E				
2 Stage limited free lift	V270	2,720	2,085	2,070	120	8	10	3,500	4,000	4,500	3,500	4,000	4,500	3,500	4,000	4,500	3,500	4,000	4,500	5,864	6,328	6,741	6,019	6,434	6,850
	*V300	3,020	2,235	2,220	120	8	10	3,500	4,000	4,500	3,500	4,000	4,500	3,500	4,000	4,500	3,500	4,000	4,500	5,894	6,358	6,771	6,049	6,464	6,880
	V330	3,320	2,385	2,370	120	8	10	3,500	4,000	4,500	3,500	4,000	4,500	3,500	4,000	4,500	3,500	4,000	4,500	5,932	6,396	6,809	6,087	6,502	6,918
	V350	3,520	2,535	2,520	120	8	10	3,500	4,000	4,500	3,500	4,000	4,500	3,500	4,000	4,500	3,500	4,000	4,500	5,955	6,419	6,832	6,110	6,525	6,941
	V370	3,720	2,635	2,620	120	8	10	3,500	4,000	4,500	3,500	4,000	4,500	3,500	4,000	4,500	3,500	4,000	4,500	5,975	6,439	6,852	6,130	6,545	6,961
	V400	4,020	2,845	2,830	120	8	10	3,500	4,000	4,500	3,500	4,000	4,500	3,400	3,900	4,400	3,500	3,950	4,400	4,900	6,018	6,482	6,894	6,172	6,588
2 Stage full free lift	V450	4,520	3,095	3,080	120	6	6	3,500	4,000	4,450	3,500	4,000	4,500	3,300	3,800	4,200	3,350	3,750	4,200	6,130	6,594	7,007	6,285	6,700	7,116
	V500	5,020	3,345	3,330	120	6	6	3,400	3,900	4,300	3,450	3,950	4,350	3,200	3,700	4,050	3,250	3,700	4,050	6,181	6,645	7,058	6,336	6,751	7,167
	VF280	2,805	2,135	2,120	1,258	6	8	3,500	4,000	4,500	3,500	4,000	4,500	3,500	4,000	4,500	3,500	4,000	4,500	5,905	6,369	6,777	6,057	6,472	6,886
	VF300	3,005	2,235	2,220	1,358	6	8	3,500	4,000	4,500	3,500	4,000	4,500	3,500	4,000	4,500	3,500	4,000	4,500	5,931	6,395	6,803	6,083	6,498	6,912
	VF315	3,155	2,325	2,310	1,448	6	8	3,500	4,000	4,500	3,500	4,000	4,500	3,500	4,000	4,500	3,500	4,000	4,500	5,951	6,414	6,822	6,103	6,517	6,931
	TF370	3,730	2,035	2,020	812	6	6	3,500	4,000	4,500	3,500	4,000	4,500	3,350	3,900	4,350	3,450	3,950	4,350	4,800	6,121	6,585	6,998	6,276	6,656
3 Stage full free lift	TF400	4,030	2,135	2,120	912	6	6	3,500	4,000	4,500	3,500	4,000	4,500	3,300	3,850	4,300	3,400	3,850	4,250	6,151	6,615	7,028	6,306	6,686	7,139
	TF430	4,330	2,235	2,220	1,012	6	6	3,450	4,000	4,450	3,500	4,000	4,500	3,250	3,750	4,200	3,300	3,800	4,200	6,182	6,646	7,059	6,337	6,717	7,170
	TF450	4,510	2,295	2,290	1,072	6	6	3,400	4,000	4,400	3,500	4,000	4,450	3,200	3,800	4,150	3,300	3,800	4,150	6,201	6,665	7,078	6,356	6,736	7,189
	TF470	4,720	2,385	2,390	1,162	6	6	3,350	3,950	4,350	3,450	4,000	4,350	3,150	3,700	4,100	3,250	3,750	4,050	6,237	6,701	7,114	6,392	6,772	7,226
	TF500	5,020	2,485	2,470	1,262	6	6	3,300	3,850	4,250	3,400	3,900	4,300	3,100	3,600	4,000	3,200	3,650	4,000	6,261	6,724	7,137	6,415	6,795	7,249
	TF550	5,520	2,665	2,650	1,442	6	6	3,000	3,600	4,000	3,300	3,750	4,150	2,850	3,350	3,850	3,100	3,500	3,850	6,322	6,785	7,199	6,476	6,856	7,310
TF600	6,030	2,845	2,830	1,622	6	6	2,600	3,100	3,400	3,200	3,650	4,000	2,450	2,950	3,250	3,000	3,400	3,750	6,390	6,854	7,267	6,545	6,925	7,378	

Mast Specification (50DA-7E)

Mast Type	Maximum Fork Height (mm)	Overall Height (Lowered) (mm)		Free Lift Height (mm)		Tilt Angle (deg)		Load Capacity without side shift at 600mm LC (kg)		Load Capacity with side shift at 600mmLC (kg)		Truck Weight (Unloaded) (kg)	
		Single Tire	Double Tire	With Backrest	Without Backrest	Fwd	Bwd	Single Tire		Double Tire		Single Tire	Double Tire
		50DA-7E	50DA-7E	50DA-7E	50DA-7E			50DA-7E	50DA-7E	50DA-7E	50DA-7E		
2 Stage limited free lift	V260	2,630	2,085	2,070	120	8	10	5,000	5,000	5,000	5,000	7,156	7,271
	*V290	2,930	2,235	2,220	120	8	10	5,000	5,000	5,000	5,000	7,232	7,302
	V320	3,230	2,385	2,370	120	8	10	5,000	5,000	5,000	5,000	7,206	7,322
	V340	3,430	2,535	2,520	120	8	10	5,000	5,000	4,950	4,950	7,231	7,346
	V360	3,630	2,635	2,620	120	8	10	5,000	5,000	4,900	4,900	7,247	7,363
	V390	3,930	2,845	2,830	120	8	10	5,000	5,000	4,800	4,800	7,283	7,398
2 Stage full free lift	V440	4,430	3,095	3,080	120	6	6	4,650	4,950	4,650	4,650	7,386	7,502
	V490	4,930	3,345	3,330	120	6	6	4,700	4,800	4,500	4,500	7,428	7,544
	VF270	2,697	2,135	2,120	905	6	8	5,000	5,000	4,700	4,750	7,215	7,327
	VF290	2,897	2,235	2,220	1,005	6	8	4,900	5,000	4,650	4,700	7,240	7,352
	VF305	3,047	2,325	2,310	1,095	6	8	4,800	4,900	4,550	4,600	7,258	7,370
	3 Stage full free lift	TF360	3,672	2,035	2,020	807	6	6	5,000	5,000	4,700	4,800	7,399
TF390		3,972	2,135	2,120	907	6	6	4,950	5,000	4,650	4,700	7,425	7,529
TF420		4,272	2,235	2,220	1,007	6	6	4,850	4,950	4,550	4,600	7,450	7,554
TF440		4,452	2,295	2,280	1,067	6	6	4,800	4,900	4,500	4,550	7,467	7,570
TF460		4,662	2,385	2,370	1,157	6	6	4,700	4,800	4,450	4,500	7,490	7,594
TF490		4,962	2,485	2,470	1,257	6	6	4,650	4,750	4,350	4,450	7,515	7,619
TF540	5,462	2,665	2,650	1,437	6	6	4,500	4,600	4,250	4,300	7,567	7,671	
TF590	5,972	2,845	2,830	1,617	6	6	4,100	4,450	4,100	4,200	7,608	7,711	

* Standard

Load Capacity

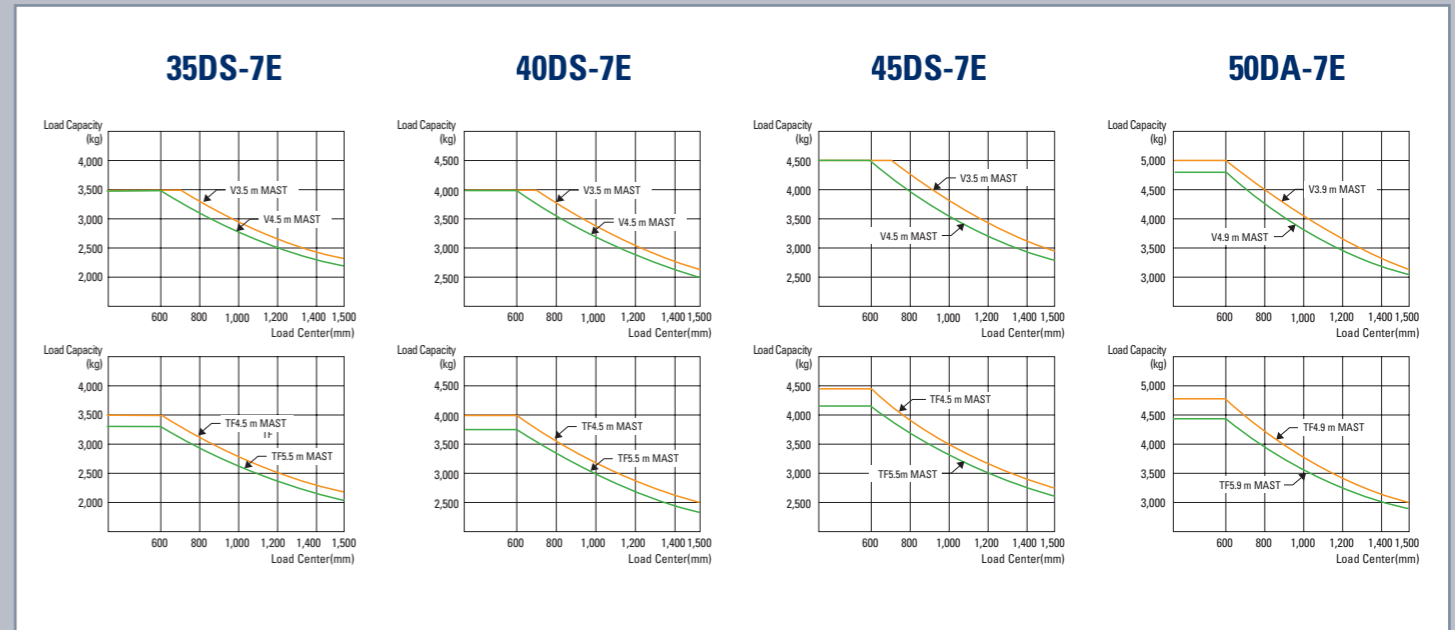

Various Attachments

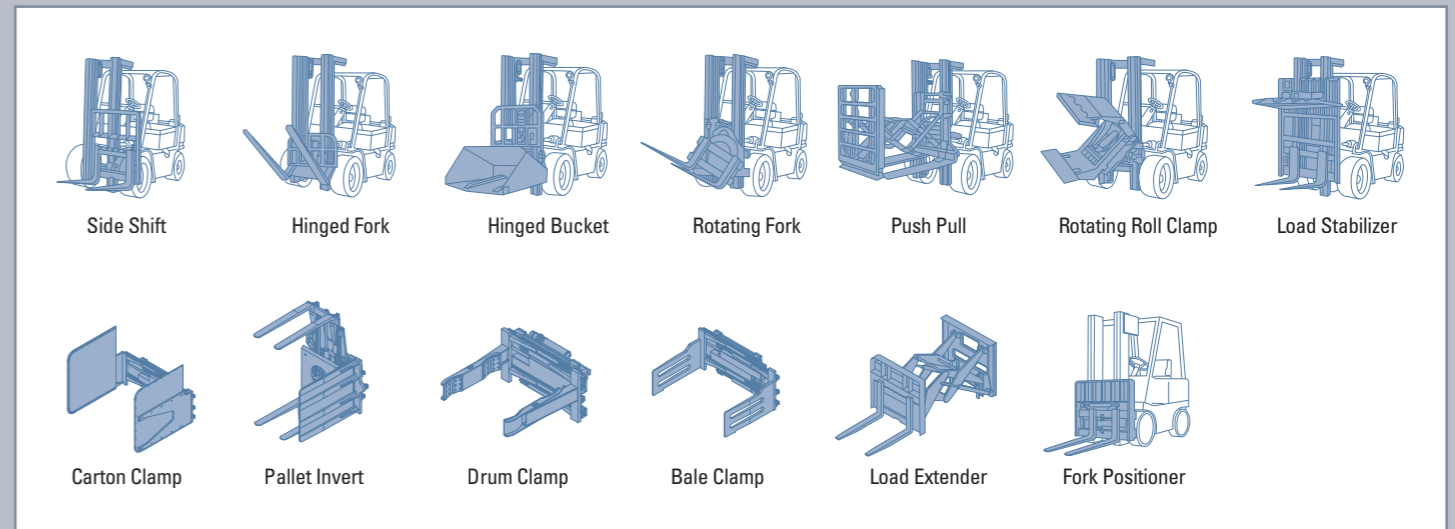

Optional Items

- FORK (LxWxT)(mm)**
- 35DS-7E (HOOK TYPE)**
 - 1,220 X 122 X 50 · 1,370 X 122 X 50 · 1,520 X 122 X 50
 - 1,670 X 122 X 50 · 1,820 X 122 X 50 · 1,970 X 122 X 50
- 35DS-7E (SHAFT TYPE)**
 - 1,220 X 150 X 50 · 1,370 X 150 X 50 · 1,520 X 150 X 50
 - 1,670 X 150 X 50 · 1,820 X 150 X 50 · 1,970 X 150 X 50
- 40DS-7E (SHAFT · HOOK TYPE)**
 - 1,070 X 150 X 50 · 1,370 X 150 X 50 · 1,520 X 150 X 50
- 45DS-7E (HOOK TYPE)**
 - 1,670 X 150 X 50 · 1,820 X 150 X 50 · 1,970 X 150 X 50
- 45DS-7E (SHAFT TYPE)**
 - 1,220 X 150 X 50 · 1,370 X 150 X 50 · 1,520 X 150 X 50
 - 1,670 X 150 X 50 · 1,820 X 150 X 50 · 1,970 X 150 X 50
- 50DA-7E (HOOK TYPE)**
 - 1,350 X 150 X 60 · 1,500 X 150 X 60 · 1,800 X 150 X 60
 - 2,000 X 150 X 60 · 2,400 X 150 X 60
- **MCV** : 3-SPOOL / 4-SPOOL / 5-SPOOL
- **SEAT** : ARM REST, HIP REST
- **SOLID TIRE**
- **OVER SHOE** : 1,500 / 1,800 / 2,000 / 2,200
- **HOSE-REEL**
- **OVER HEAD GUARD HEIGHT** : 2,500 / 2,340
- **CABIN (HEIGHT 2,240)**
- **CABIN + HEATER**