

Optional Items

- FORK (L x W x T)(mm)
 - 110D-7E
75 x 200 x 1,200 / 75 x 200 x 1,500 / 75 x 200 x 1,650 / 75 x 200 x 1,800 / 75 x 200 x 2,100 / 85 x 200 x 2,440
 - 130D-7E
85 x 200 x 1,200 / 85 x 200 x 1,500 / 85 x 200 x 1,650 / 85 x 200 x 1,800 / 85 x 200 x 2,100 / 90 x 200 x 2,440
 - 140D-7E
85 x 200 x 1,200 / 90 x 200 x 1,500 / 90 x 200 x 1,650 / 90 x 200 x 1,800 / 90 x 200 x 2,100 / 90 x 200 x 2,440
 - 160D-7E
90 x 200 x 1,200 / 90 x 200 x 1,500 / 90 x 200 x 1,650 / 95 x 200 x 1,800 / 95 x 200 x 2,100 / 95 x 200 x 2,440
- MAST : SIMPLEX MAST / TRIPLEX MAST
- OVER SHOE: 1,800 / 2,000 / 2,200 / 2,400 / 2,600
- MCV : 4 - SPOOL / 5 - SPOOL
- SEAT : NON HEAT / HEAT
- BEACON LAMP : AMBER / RED / BLUE
- FORK POSITIONER : 82 / 100
- INTEGRAL SIDE SHIFT
- INTEGRAL SIDE SHIFT + FORK POSITIONER
- HYDRAULIC LINE: 3 - SPOOL / 4 - SPOOL / 5 - SPOOL
- SOLID TIRE
- PNEUMATIC TIRE : LUG / SMOOTH(14/16 ONLY)
- WIDE CARRIAGE (2,730 mm)
- HEAD GUARD

Various Attachments

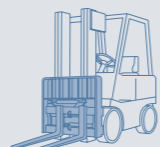

Fork Positioner

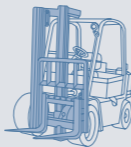

Side Shift



110D/130D/140D/160D -7E



■ Some of the photos may include optional equipment.

HYUNDAI DIESEL FORKLIFT TRUCKS **Applied Tier 3 Engine**

110D/130D/140D/160D-7E

 **HYUNDAI**
HEAVY INDUSTRIES CO.,LTD.

ООО "ЮЖУРАЛПОГРУЗЧИК"
454085, РФ, г. Челябинск, ул.
Танкистов, 179 корпус Б
Тел/факс: 8-351- 270-20-55, 755-52-70
2702055@mail.ru
www.uralforklift.ru

 **HYUNDAI**
HEAVY INDUSTRIES CO.,LTD.

We build a better future

■ Contact your Hyundai dealer for more information. The machine shown may vary according to International standards.

NEW criterion of Big Forklift Truck

Hyundai introduces a new line of 7E-series diesel forklift trucks. Excellent power and performance makes your business more profitable.

Excellent



Cruise Control



Instrument Switch Panel



Air Conditioner & Heater



Rear View Camera



Rear View Monitor



ESL(Engine Start Limit)

■ Some of the photos may include optional equipment.

Ability of best, the new master on the job-site!

Smooth running, efficient and ergonomically designed, 110D/130D/140D/160D-7E series are made to meet your needs.



Powerful Engine

Cummins QSB6.7 Engine

The six cylinders turbo-charged engine is built for power, reliability and economy. This engine meets EPA Tier 3 and EU stage IIIA emission regulation.



Engine Control Mode

According to operating load, the operator can select engine mode by changing side panel switch.

STD Mode : Fuel reduction mode for light-duty operating load

POWER Mode : Heavy-duty or operating at slope



Adjustable Engine Low Idle RPM

While engine runs, low idle rpm can be increased by unit of 25rpm and it keeps previously set rpm when engine restarts.

162ps / 2,200rpm
74.6kgf-m / 1,400rpm

Full-automatic Transmission

Full-automatic transmission gives easy, convenient handling and soft, smooth shifting. The operator can select two kinds of automatic modes. (1st→3rd, 2nd→3rd)



Cruise Control

It offers the ability to automatically maintain a desired engine speed with no accelerator pedal input and reduce fuel consumption.



Transmission Control Switch



Excellent Night Work

- Variety position of work lamp provides the operator more comfortable and safe operating environments.
- Front : fender(2), mast(2) - Rear : cab(2)



Increased Mast Tilting Angle

Utilizing the mast tilting angle of 15 degrees forward and 12 degrees backward, the operator can perform loading and unloading jobs safely and rapidly.

Faster Travel Speed & Better Gradability

The powerful high-output engine provides greater acceleration, better gradability and faster travel speed on any tough terrains or slopes.



Gradability(Loaded)

110D-7E : 36.8 % 140D-7E : 30.0%
130D-7E : 33.2% 160D-7E : 27.5%

Travel Speed(Unloaded)

110D-7E : 35.0km/h
130D-7E : 34.8km/h
140D-7E : 33.8km/h
160D-7E : 33.6km/h



Some of the photos may include optional equipment.

Ergonomic driving space design!

A design based on human engineering relieves fatigue and increases operator's efficiency.

Operator Friendly Gauges and Water-resistant Monitor Panel



Easily Adjustable Suspension Seat

An attractive and adjustable seat, based on a human engineering design, provides great comfort, safety and durability. (Head Rest - option)

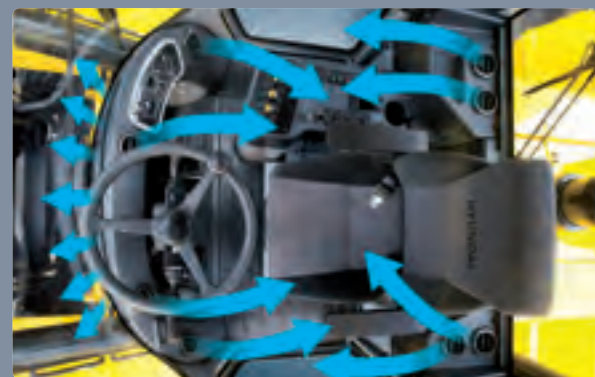

High-output Air Conditioner & Heater

An air conditioner with integrated the condenser is mounted on upper side of the cabin to make a wide room in the cabin. And an air conditioner with high-output and heater always provide you comfortable environment when you work.



Some of the photos may include optional equipment.



ESL(Engine Start Limit) / Rear View Camera Monitor
Engine starting is possible after password verifying, when password is not correct, intercepts the fuel injection of engine. Whether to use ESL can be selected from the menu of the monitor. The rear view camera makes the operation more easy and convenient. And it supports 4 camera channels.



Centralized Instrument Switch Panel



MP3 CD Player & Remote Control



Hands Free Socket



Quick Response of Operating Control Levers
Only minimal operator's effort is required for precise, safe and productive control. (3-Lever : standard / 4-Lever : option)



Ergonomically Positioned Pedals
Based on human engineering ; the accelerator, brake and inching pedals are optimally positioned for the operator's convenience.



Adjustable Steering Column

Steering handle is adjustable depending on the operator's body shape. Adjustability of steering column makes you more comfortable.



Danger-free through high durability!

Safety and durability are priorities in design of the equipment.



Up-to-date Cooling System

The minimum fuel consumption and low noise are available by applying hydraulic cooling fan sensing intake air temperature, transmission oil temperature, coolant temperature and hydraulic temperature.



OPSS(Operator Presence Sensing System)

Control of mast tilting, lifting and lowering is not possible through operation of the appropriate control when the operators is not in the normal position.

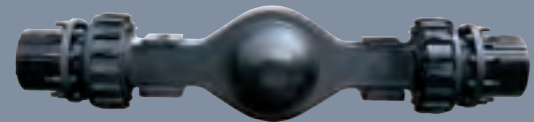

Durable Drive Axle

The hypoid type planetary reduction drive axle smoothly delivers desired torque to the drive wheels.

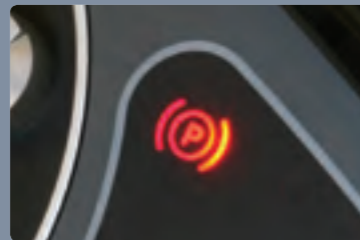

Auto Parking

The parking brake is engaged automatically when the transmission is neutral and the operator leaves the seat.



■ Some of the photos may include optional equipment.



Wet Disc Brake System

The wet disc brake system is virtually maintenance free and is enclosed to protect from dust and water.



Fitted Protector for Hub Bolts

Durability has improved by applying protector for preventing bolts breakage. (Easy parts supply due to the wheel in common with front wheel)



Cylinder Guard

This guard helps to prevent possible damage from any foreign material.



Grease Fittings

Grease fittings are installed for fast access to steering axle center pin when doing your service checks.



Highly Durable Mast & Carriage Side Roller

Side roller with great durability for mast and carriage is included.



Highly Durable Carriage

The carriage is very strong cause of applying the high tensile structural steel which has a excellent durability. Work at the narrow space is easy because the width of carriage is narrower then overall width of the vehicle.



Large Footboard & Handle

Wide "open" step offers convenience and safety when entering and exiting the truck.

Centralized design for easy service!

An ideal arrangement of component parts ensures easy access and convenience for maintenance.



Large Engine Hood

Highly accessible engine compartment assures fast and efficient maintenance.



Easy Change Air Cleaner

This air filter is readily accessible for cleaning or replacement.



Cabin Tilting Automatic System

Cabin tilting automatic system makes servicing of all power train components quick and easy. An electrically assisted hydraulic actuated cylinder tilts operator cabin to left side about 65 degrees for easy access to inside of truck components.



Cabin Air Fresh Filter

The internal pressure is maintained to be slightly higher than that of outside to exclude dust and to reduce noise levels.



Some of the photos may include optional equipment.



Compact fuse Box for Easy Inspection



Mechanic Friendly Fuel Filter Replacement

Highly accessible engine compartment allows for quick replacement of filters.



Electrically Monitored Air Filter

Air cleaner sensor alerts the operator of a clogged air filter and allows replacement before damage.



Automatic Self Locking Gas Spring

Engine compartment hood is safely opened by a self locking gas spring.



Master Switch

A master switch disconnects the battery power to protect the electrical system from excess electrical drainage.



Large Tool Box



Pressure Gauge Port



Easy Maintenance Oil Check

Mast Specification

Mast Type	Maximum Fork Height (mm)	Overall Height Lowerd (mm)	Tilt Angle (mm)	Load Capacity (600mm LC)(kg)		Truck Weight Unloaded (kg)		
				110D/130D-7E	110D-7E	130D-7E	110D-7E	130D-7E
2-Stage Limited Free Lift	V300	3,005	3,000	15 / 12	11,000	13,000	15,722	16,427
	* V330	3,305	3,150	15 / 12	11,000	13,000	15,797	16,503
	V350	3,505	3,250	15 / 12	11,000	13,000	15,847	16,552
	V400	4,005	3,550	15 / 12	11,000	13,000	16,100	16,805
	V450	4,505	3,800	15 / 12	11,000	12,600	16,225	16,930
	V500	5,005	4,100	15 / 12	11,000	12,200	16,374	17,079
	V550	5,505	4,350	15 / 12	11,000	11,800	16,605	17,310
	V600	6,005	4,650	15 / 12	10,600	11,400	16,757	17,462
	V650	6,505	4,900	15 / 12	10,300	11,100	16,890	17,595
3-Stage Full Free Lift	V700	7,005	5,150	15 / 12	10,000	10,800	17,021	17,726
	TF440	4,405	2,950	10 / 10	11,000	12,300	16,761	17,467
	TF470	4,705	3,050	10 / 10	11,000	12,100	16,832	17,538
	TF500	5,005	3,150	10 / 10	11,000	11,800	16,903	17,609
	TF550	5,505	3,317	10 / 10	10,600	11,500	17,070	17,776
	TF600	6,005	3,484	10 / 10	10,300	11,100	17,188	17,894
	TF650	6,505	3,651	10 / 10	9,600	10,800	17,402	18,108
TF700	7,005	3,818	10 / 10	8,700	10,500	17,521	18,227	

Mast Type	Maximum Fork Height (mm)	Overall Height Lowerd (mm)	Tilt Angle (mm)	Load Capacity (600mm LC)		Truck Weight Unloaded (kg)		
				140D/160D-7E	140D-7E	160D-7E	140D-7E	160D-7E
2-Stage Limited Free Lift	V295	2,950	2,950	15 / 12	14,000	16,000	18,120	18,977
	V300	3,010	3,250	15 / 12	14,000	16,000	18,284	19,141
	* V330	3,310	3,400	15 / 12	14,000	16,000	18,378	19,235
	V350	3,510	3,500	15 / 12	14,000	16,000	18,423	19,280
	V400	4,010	3,750	15 / 12	14,000	16,000	18,710	19,567
	V450	4,510	4,000	15 / 12	14,000	15,900	18,865	19,722
	V500	5,010	4,300	15 / 12	14,000	15,900	19,047	19,904
	V550	5,510	4,550	15 / 12	13,600	15,200	19,316	20,173
	V600	6,010	4,850	15 / 12	13,200	14,600	19,498	20,355
3-Stage Full Free Lift	V650	6,510	5,125	15 / 12	12,800	14,100	19,664	20,521
	V700	7,010	5,375	15 / 12	12,500	13,800	19,815	20,672
	TF395	3,964	2,950	10 / 10	14,000	15,600	19,385	20,254
	TF450	4,504	2,950	10 / 10	13,900	15,300	19,546	20,415
	TF500	5,004	3,297	10 / 10	13,500	14,900	19,721	20,590
	TF550	5,504	3,464	10 / 10	12,900	14,500	19,904	20,773
	TF600	6,004	3,631	10 / 10	12,600	14,100	20,059	20,923
TF650	6,504	3,798	10 / 10	12,200	13,700	20,338	21,207	
TF700	7,004	3,965	10 / 10	11,900	13,400	20,481	21,350	

Load Capacity

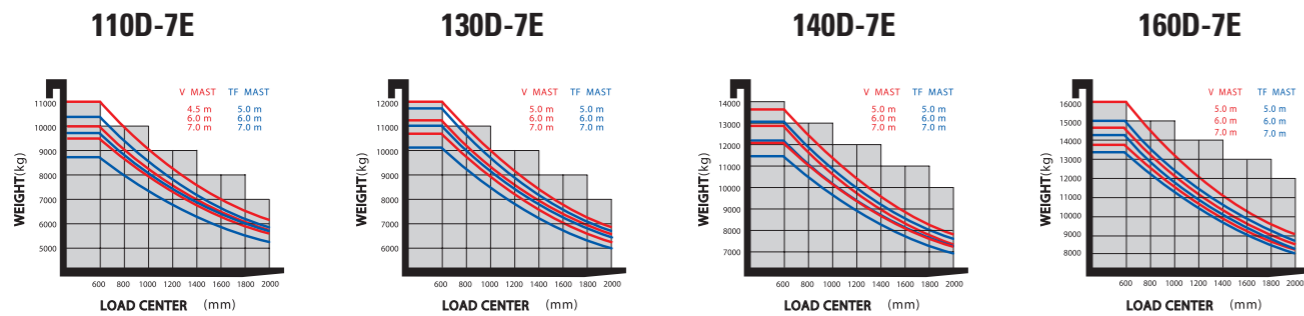

Dimension

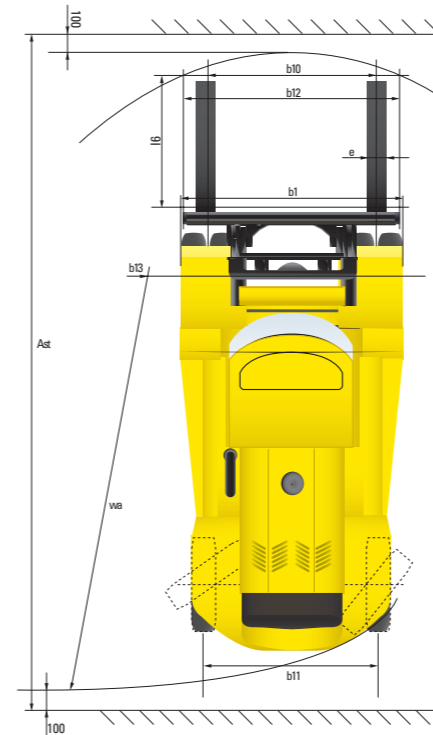
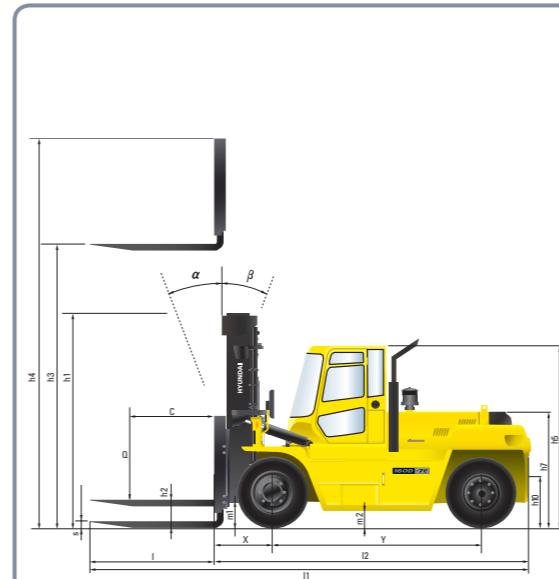

Specification

Identification						
1.1	Manufacturer	Hyundai	Hyundai	Hyundai	Hyundai	
1.2	Manufacturer's type designation	110D-7E	130D-7E	140D-7E	160D-7E	
1.3	Drive: electric (battery or mains),diesel,petrol,fuel gas,manual	DIESEL	DIESEL	DIESEL	DIESEL	
1.4	Type of operation:hand,pedestrian,standing,seated,order-picker	seated	seated	seated	seated	
1.5	Load capacity / rated load	Q (t)	11.0	13.0	14.0	16.0
1.6	Load center distance	c (mm)	600	600	600	600
1.8	Load distance, center of drive axle to fork	x(mm)	755	760	830	835
1.9	Wheelbase	y(mm)	2,900	2,900	3,300	3,300
Weights						
2.1	Service weight	kg	15,797	16,503	18,378	19,235
2.2	Axle loading, loaded front/rear	kg	23,844 / 7,704	26,702 / 7,605	29,350 / 9,283	32,199 / 9,241
2.3	Axle loading, unloaded front/rear	kg	2,625 / 7,765	2,802 / 8,898	3,028 / 9,095	3,036 / 9,994
Wheels, Chassis						
3.1	Tires:solid rubber, superplastic, pneumatic, polyurethane	Pneumatic	Pneumatic	Pneumatic	Pneumatic	
3.2	Tires size, front(width x Φ)	10.0 - 20	10.0 - 20	12.0 - 20	12.0 - 20	
3.3	Tires size, rear(width x Φ)	10.0 - 20	10.0 - 20	12.0 - 20	12.0 - 20	
3.5	Wheels, number front x rear (x=driven wheels)	4 x 2	4 x 2	4 x 2	4 x 2	
3.6	Track width, front	b10 (mm)	1,842	1,842	1,842	1,842
3.7	Track width, rear	b11 (mm)	1,910	1,910	1,955	1,955
Basic Dimensions						
4.1	Mast / fork carriage tilt forward / backward(α / β)	degrees	15 / 12	15 / 12	15 / 12	15 / 12
4.2	Lowered mast height	h1 (mm)	3,000	3,000	3,250	3,250
4.3	Free lift	h2 (mm)	0	0	0	0
4.4	Lift height	h3 (mm)	3,005	3,005	3,010	3,010
4.5	Extended mast height	h4 (mm)	4,465	4,465	4,710	4,710
4.7	Overhead load guard (cab) height	h5 (mm)	2,900	2,900	2,935	2,935
4.8	Seat height / standing height	h7 (mm)	1,723	1,723	1,749	1,749
4.12	Coupling height	h10 (mm)	600	600	600	600
4.19	Overall length	l1 (mm)	5,690	5,695	6,250	6,255
4.20	Length to face of forks	l2 (mm)	4,340	4,345	4,900	4,905
4.21	Overall width	b1 (mm)	2,450	2,450	2,497	2,497
4.22	Fork dimensions	s / e / l(mm)	75 x 200 x 1,350	85 x 200 x 1,350	85 x 200 x 1,350	90 x 200 x 1,350
4.23	Fork carriage ISO 2328, class / type A,B	Pin Mount	Pin Mount	Pin Mount	Pin Mount	Pin Mount
4.24	Fork-carriage width	b12 (mm)	2,357	2,357	2,497	2,497
4.31	Ground clearance, loaded, under mast	m1(mm)	270	270	270	270
4.32	Ground clearance, centre of wheelbase	m2(mm)	330	330	330	330
4.33	Aisle width for pallets 1000x1200 crossways	Ast(mm)	6,385	6,390	6,960	6,965
4.34	Aisle width for pallets 800x1200 lengthways	Ast(mm)	6,385	6,390	6,960	6,965
4.35	Turning radius	Wa(mm)	4,080	4,080	4,580	4,580
4.36	Smallest pivot point distance	b13(mm)	1,516	1,516	1,748	1,748
Performance Data						
5.1	Travel speed, Unloaded	km/h	35	34.8	33.8	33.6
5.2	Lift speed, Loaded/Unloaded	m/s	0.44 / 0.51	0.43 / 0.51	0.36 / 0.45	0.35 / 0.45
5.3	Lowering speed, Loaded/Unloaded	m/s	0.51 / 0.46	0.51 / 0.46	0.43 / 0.39	0.43 / 0.39
5.5	Drawbar pull, Loaded	N	90,817	91,405	91,385	91,718
5.7	Gradient performance, Loaded	%	36.9	33.2	30.0	27.5
5.9	Acceleration time, Loaded/ Unloaded(10m)	sec	-	-	-	-
5.10	Service brake	hydraulic	hydraulic	hydraulic	hydraulic	
Engine						
6.1	Engine manufacturer / type	Cummins QSB6.7	Cummins QSB6.7	Cummins QSB6.7	Cummins QSB6.7	
6.2	Engine power acc. to ISO 1585	kW	119	119	119	119
6.3	Rated speed	1/min	2,200	2,200	2,200	2,200
6.4	No. of cylinder / cubic capacity	/cm³	6 / 6,700	6 / 6,700	6 / 6,700	6 / 6,700
6.5	Fuel consumption acc. To VDI cycle	l / h	11.0	11.0	11.5	11.5
Other Details						
8.1	Type of drive control	Torque Convert	3 / 3	3 / 3	3 / 3	3 / 3
8.2	Operating pressure for attachments	bar	150	150	150	150
8.3	Oil volume for attachments	l/min	295	295	295	295
8.4	Sound level at driver's ear according to DIN 12 053	db(A)	82	82	82	82
8.5	Tow coupling, type DIN	-	-	-	-	