

Dimension

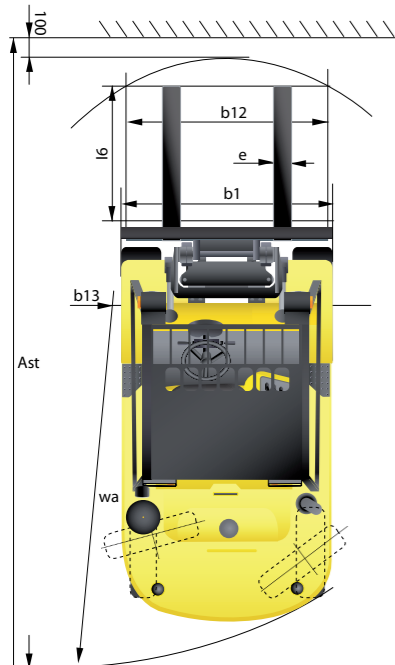

Specification

Identification						
1.1	Manufacturer	Hyundai	Hyundai	Hyundai	Hyundai	
1.2	Manufacturer's type designation	35D-7E	40D-7E	45D-7E	50D-7AE	
1.3	Drive: electric (battery or mains), diesel, petrol, fuel gas, manual	DIESEL	DIESEL	DIESEL	DIESEL	
1.4	Type of operation: hand, pedestrian, standing, seated, order-picker	seated	seated	seated	seated	
1.5	Load capacity / rated load	kg	3,500	4,000	4,500	5,000
1.6	Load center distance	c(mm)	600	600	600	600
1.8	Load distance, center of drive axle to fork	x(mm)	561	561	561	576
1.9	Wheel base	y(mm)	2,000	2,000	2,000	2,000
Weights						
2.1	Service weight	kg	5,894	6,464	6,880	7,302
2.2	Axle loading, loaded front/rear	kg	8,371 / 1,024	9,291 / 1,173	10,088 / 1,292	10,928 / 1,373
2.3	Axle loading, unloaded front/rear	kg	2,841 / 3,054	2,971 / 3,493	2,978 / 3,902	2,988 / 4,313
Wheels, Chassis						
3.1	Tires: solid rubber, superelastic, pneumatic, polyurethane		pneumatic	pneumatic	pneumatic	pneumatic
3.2	Tires size, front (Φ x width)		8.25-15-14	7.50-16-12	7.50-16-12	7.50-16-12
3.3	Tires size, rear (Φ x width)		7.00-12-12	7.00-12-12	7.00-12-12	7.00-12-14
3.5	Wheels, number front x rear (x=driven wheels)		2 x 2	4 x 2	4 x 2	4 x 2
3.6	Track width, front	mm	1,132	1,282	1,282	1,282
3.7	Track width, rear	mm	1,140	1,140	1,140	1,140
Basic Dimensions						
4.1	Mast / fork carriage tilt forward / backward (α/β)	degrees	8 / 10	8 / 10	8 / 10	8 / 10
4.2	Lowered mast height	h1 (mm)	2,235	2,200	2,200	2,200
4.3	Free lift	h2 (mm)	120	120	120	120
4.4	Lift height	h3 (mm)	3,000	3,000	3,000	2,900
4.5	Extended mast height	h4 (mm)	4,236	4,236	4,246	4,246
4.7	Overhead guard height (low opt / std / high opt)	h5 (mm)	2,200 / 2,240 / 2,340	2,200 / 2,240 / 2,340	2,200 / 2,240 / 2,340	2,200 / 2,240 / 2,340
4.8	Seat height / standing height	h7 (mm)	1,100	1,100	1,100	1,100
4.12	Coupling height	h10 (mm)	364	364	364	364
4.19	Overall length	l1 (mm)	4,140	4,195	4,405	4,450
4.20	Length to face of forks	l2 (mm)	3,140	3,195	3,245	3,315
4.21	Overall width	b1 (mm)	1,370	1,746	1,746	1,746
4.22	Fork dimensions (hook type)	s / e / l (mm)	50 x 122 x 1,070	50 x 150 x 1,070	50 x 150 x 1,220	60 x 150 x 1,200
4.23	Fork carriage ISO 2328, class / type A,B		III / A	III / A	IV / A	IV / A
4.24	Fork-carriage width	b3 (mm)	1,300	1,600	1,600	1,600
4.31	Ground clearance, loaded, under mast	m1 (mm)	170	155	155	155
4.32	Ground clearance, centre of wheelbase	m2 (mm)	215	200	200	200
4.33	Aisle width for pallets 1,000x1,200 crossway (LxW)	Ast (mm)	4,601	4,661	4,711	4,781
4.34	Aisle width for pallets 800x1,200 lengthway (WxL)	Ast (mm)	4,801	4,861	4,911	4,981
4.35	Turning radius	Wa (mm)	2,840	2,900	2,950	3,020
4.36	Smallest pivot point distance	mm	999	999	999	999
Performance Data						
5.1	Travel speed, unloaded	km/h	27.7	26.7	26.7	26.6
5.2	Lift speed, loaded / unloaded	mm/s	550 / 570	540 / 570	530 / 570	460 / 490
5.3	Lowering speed, loaded / unloaded	mm/s	500 / 500	500 / 500	500 / 500	500 / 500
5.5	Drawbar pull, loaded	kg	4,015	4,035	4,042	4,050
5.7	Gradient performance, loaded	%	42.0	37.3	33.9	31.0
5.9	Acceleration time, loaded / unloaded (10m)		-	-	-	-
5.10	Service brake		hydraulic	hydraulic	hydraulic	hydraulic
Engine						
6.1	Engine manufacturer / type		HMC D4DD	HMC D4DD	HMC D4DD	HMC D4DD
6.2	Engine power acc. to ISO 1585	kW	70	70	70	70
6.3	Rated speed	1/min	2,300	2,300	2,300	2,300
6.4	No. of cylinder / cubic capacity	cm ³	3,907	3,907	3,907	3,907
6.5	Fuel consumption acc. To VDI cycle	l/h	3.2	3.4	3.63	3.83
Other Details						
8.1	Type of drive control		Torque Converter 2/2	Torque Converter 2/2	Torque Converter 2/2	Torque Converter 2/2
8.2	Operating pressure (system / attach)	bar	210	210	210	210
8.3	Oil volume (hydraulic)	l	66	66	66	66
8.4	Noise (at driver's ear according to DIN 12053)	db(A)	82	82	82	82

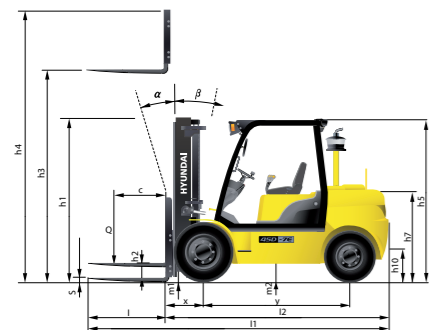

Some of the photos may include optional equipment

HYUNDAI DIESEL FORKLIFT TRUCKS Applied Tier 3 Engine

35D/40D/45D-7E

50D-7AE

We build a better future

Contact your Hyundai dealer for more information. The machine shown may vary according to International standards.



ООО "ЮЖУРАЛПОГРУЗЧИК"
 454085, РФ, г. Челябинск, ул.
 Танкистов, 179 корпус Б
 Тел/факс: 8-351-270-20-55, 755-52-70
 2702055@mail.ru
www.uralforklift.ru



35/40/45D -7E

50D -7AE

New criteria of forklift trucks

Hyundai introduces a new line of 7E series diesel forklift trucks. Excellent power and performance make your business more profitable.



■ Some of the photos may include optional equipment.

The new master on the job-site!

Smooth running, efficient and ergonomically designed, 35/40/45D-7E, 50D-7AE series are made to meet your needs.



HMC D4DD

High power engine - HMC D4DD

Market approved quality of HMC D4DD engine ensures incomparable performance, durability and excellent fuel efficiency. This engine meets EPA Tier-III and EU stage IIIA emission regulations.

70kW/2,300rpm
35kgf-m/1,600rpm



Fast and stable performance

Being able to quickly raise and lower the mast, as well as tilt it forward and backward, providing the best operational conditions during unloading. When the truck is fully loaded, mast lowering speed is carefully controlled to ensure safety by the down control valve.

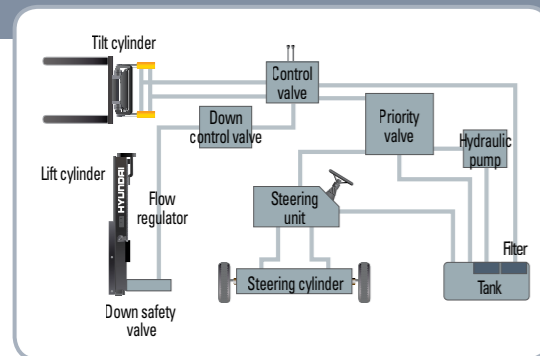

State-of-the-art hydraulic system

The latest large-capacity hydraulic system reacts quickly during operation, and a low-noise control valve increases both efficiency and durability.



OPSS (Operator Presence Sensing System)

Control of mast tilting, lifting and lowering is not possible through operation of the appropriate control when the operator is not in the seated position. (Option)



Fully hydrostatic power steering

A hydraulic steering system always guarantees smooth and flexible steering, preventing overrun and kick-back.



Increased mast tilting angle

The mast tilting angle of 8 degrees forward and 10 degrees backward, the operator can safely and rapidly perform loading and unloading jobs.



Some of the photos may include optional equipment.

Faster travel speed & gradeability

The powerful high-output engine provides greater acceleration, better gradeability and faster travel speed on any tough terrain or slope.



Travel speed(Unloaded)

35D-7E : 27.7km/h 45D-7E : 26.7km/h
40D-7E : 26.7km/h 50D-7AE : 26.6km/h

Gradeability(Loaded)

35D-7E : 42.0%
40D-7E : 37.3%
45D-7E : 33.9%
50D-7AE : 31.0%

Ergonomic operator friendly compartment design!

A design based on human engineering relieves fatigue and increases operator's efficiency.

Operator friendly gauges and water-resistant monitor panel



- 1 Parking brake lamp
- 2 Directional indicators
- 3 Fuel warning lamp
- 4 Engine oil warning lamp
- 5 Transmission oil temperature warning lamp
- 6 Battery charging warning lamp
- 7 Air cleaner filter warning light
- 8 Working light indicator
- 9 Water separator lamp
- 10 Pre-heater indicator
- 11 Water temperature gauge
- 12 Fuel gauge
- 13 Hour meter
- 14 Engine check lamp
- 15 Seat belt warning
- 16 OPS warning



Easily adjustable suspension seat

An attractive and adjustable seat, based on a human engineering design, provides great comfort, safety and durability.

New high visibility for safe operation

The operator is able to work with increased safety and accuracy due to a wider view mast.



■ Some of the photos may include optional equipment.



Ergonomically positioned pedals

Based on human engineering, the accelerator, brake and inching pedals are optimally positioned for convenience while operating the equipment.



Cup holder & console box

Additional storage spaces are located inside the operating space for operator's convenience.



Quick response of operating control levers

Only minimal operator's effort is required for precise, safe and productive control.

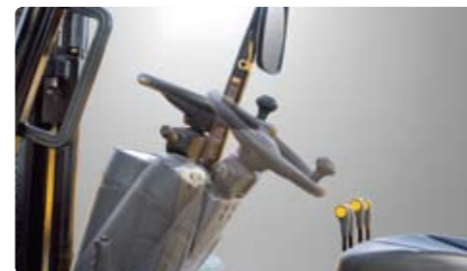

Adjustable steering wheel

Steering wheel with horn button can be adjusted by a lever on the right-hand side for the most comfortable operator position.



Easy and safe shift lever

A single lever on the left side of the steering column gives the operator fast, easy control of direction. The lever must be in the neutral position before the engine can be started.



Secondary Horn

Secondary Horn gives access to lights and horn.

Danger-free through high durability!

Safety and durability are priorities in the design of the equipment.



Strong overhead guard

The safety overhead guard exceeds EEC and ANSI regulations and protects the operator during hazardous jobs.



Parking brake

Ratchet type parking brake requires less efforts from the operator to set.

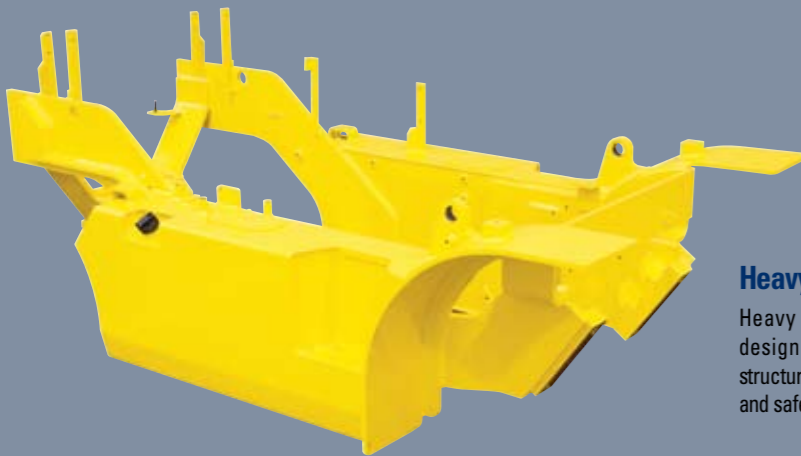

Heavy duty single unit frame

Heavy duty single unit type frame, designed on the basis of accurate structural analysis, guarantees durability and safety.



■ Some of the photos may include optional equipment.



Highly durable transmission and drive axle

Powershift transmission provides fast travel speed and quiet travel under any heavy load condition, and boosts work efficiency.



Fuel tank safety valve

Integrated safety check valve shuts off fuel supply in the unlikely condition of a truck overturn.



Expansion bellows

The expansion bellows absorbs vibration and reduces noise generated from the exhaust gas system and also extends the life cycle of exhaust gas system.



Large footboard & hand grip

Wide "open" step offers convenience and safety when entering and exiting truck.



Bright, protected headlights

Bright, protected headlights are positioned for exceptional visibility.

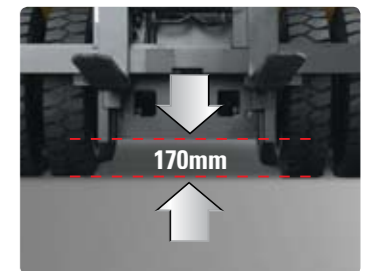

Ground clearance

The engine and transmission are assembled horizontally and positioned high in the frame to protect major components during operation on rugged surface.

Centralized design for easy service!

An ideal arrangement of component parts ensures easy accesses and conveniences for the maintenance.



Easy change air cleaner

The air filter is readily accessible for cleaning or replacement. (7inch Cyclone Type)



■ Some of the photos may include optional equipment.



Visible precleaner

Efficient, accessible pre-cleaner provides for longer engine life



Double battery installation



Easy-to-change radiator



Quick and easy engine oil check



Electrically monitored air filter

Air cleaner sensor alerts the operator of a restricted air filter and allows replacement before damage.



Easy maintenance oil check

The T/M oil level can be checked easily without any disassembly.



Brake fluid reservoir

Highly visible, easily accessible reservoir makes for quicker daily inspections.



An accessible, compact fuse box for easy inspection

Mast Specification (35/40/45D-7E)

Mast Type	Maximum Fork Height (mm)	Overall Height (Lowered) (mm)		Free Lift Height (mm)		Tilt Angle (deg)		Load Capacity without side shift at 600mm LC (kg)						Load Capacity with side shift at 600mmLC (kg)						Truck Weight (Unloaded) (kg)						
		Single Tire	Double Tire	With Backrest	Without Backrest	Fwd	Bwd	Single Tire			Double Tire			Single Tire			Double Tire			Single Tire	Double Tire					
								35D-7E	40D-7E	45D-7E	35D-7E	40D-7E	45D-7E	35D-7E	40D-7E	45D-7E	35D-7E	40D-7E	45D-7E			35D-7E	40D-7E	45D-7E		
2 Stage limited free lift	V270	2,720	2,085	2,070	120	120	8	10	3,500	4,000	4,500	3,500	4,000	4,500	3,500	4,000	4,500	3,500	4,000	4,500	5,802	6,256	6,668	5,956	6,362	6,777
	*V300	3,020	2,235	2,220	120	120	8	10	3,500	4,000	4,500	3,500	4,000	4,500	3,500	4,000	4,500	3,500	4,000	4,500	5,832	6,286	6,699	5,987	6,392	6,807
	V330	3,320	2,385	2,370	120	120	8	10	3,500	4,000	4,500	3,500	4,000	4,500	3,500	4,000	4,500	3,500	4,000	4,500	5,869	6,323	6,736	6,024	6,429	6,845
	V350	3,520	2,535	2,520	120	120	8	10	3,500	4,000	4,500	3,500	4,000	4,500	3,500	4,000	4,500	3,500	4,000	4,500	5,893	6,346	6,759	6,047	6,453	6,868
	V370	3,720	2,635	2,620	120	120	8	10	3,500	4,000	4,500	3,500	4,000	4,500	3,500	4,000	4,500	3,500	4,000	4,500	5,913	6,367	6,779	6,067	6,473	6,888
	V400	4,020	2,845	2,830	120	120	8	10	3,500	4,000	4,500	3,500	4,000	4,500	3,500	3,900	4,450	3,500	3,900	4,500	5,955	6,409	6,822	6,110	6,515	6,931
	V450	4,520	3,095	3,080	120	120	8	6	3,500	4,000	4,500	3,500	4,000	4,500	3,350	3,800	4,300	3,350	3,750	4,350	6,068	6,522	6,935	6,223	6,628	7,043
V500	5,020	3,345	3,330	120	120	8	6	3,200	3,900	4,400	3,500	4,000	4,400	3,250	3,650	4,200	3,250	3,700	4,200	6,119	6,573	6,985	6,273	6,679	7,094	
2 Stage full free lift	VF280	2,805	2,135	2,120	1,258	919	8	8	3,500	4,000	4,500	3,500	4,000	4,500	3,500	4,000	4,500	3,500	4,000	4,500	5,843	6,297	6,704	5,995	6,399	6,813
	VF300	3,005	2,235	2,220	1,358	1,019	8	8	3,500	4,000	4,500	3,500	4,000	4,500	3,500	4,000	4,500	3,500	4,000	4,500	5,869	6,323	6,731	6,021	6,425	6,839
	VF315	3,155	2,325	2,310	1,448	1,109	8	8	3,500	4,000	4,500	3,500	4,000	4,500	3,500	4,000	4,500	3,500	4,000	4,500	5,888	6,342	6,750	6,040	6,445	6,859
3 Stage full free lift	TF370	3,730	2,035	2,020	812	1,139	8	8	3,500	4,000	4,500	3,500	4,000	4,500	3,450	3,950	4,400	3,500	3,900	4,450	6,059	6,512	6,926	6,213	6,583	7,037
	TF400	4,030	2,135	2,120	912	1,239	8	8	3,500	4,000	4,500	3,500	4,000	4,500	3,400	3,850	4,350	3,400	3,850	4,350	6,089	6,542	6,955	6,243	7,067	
	TF430	4,330	2,235	2,220	1,012	1,339	8	8	3,500	4,000	4,500	3,500	4,000	4,500	3,300	3,800	4,250	3,350	3,750	4,250	6,120	6,574	6,987	6,274	7,098	
	TF450	4,510	2,295	2,290	1,072	1,399	8	8	3,450	4,000	4,500	3,500	4,000	4,500	3,300	3,800	4,200	3,300	3,750	4,250	6,138	6,592	7,005	6,293	7,117	
	TF470	4,720	2,385	2,390	1,162	1,489	8	8	3,400	3,950	4,400	3,500	4,000	4,450	3,250	3,700	4,150	3,250	3,750	4,150	6,175	6,629	7,042	6,330	7,153	
	TF500	5,020	2,485	2,470	1,262	1,589	8	8	3,350	3,850	4,350	3,450	3,850	4,350	3,150	3,600	4,050	3,200	3,600	4,100	6,198	6,652	7,065	6,353	7,176	
	TF550	5,520	2,665	2,650	1,442	1,769	8	6	3,250	3,700	4,200	3,350	3,750	4,200	2,900	3,400	3,950	3,100	3,500	3,950	6,259	6,713	7,126	6,414	7,237	
TF600	6,030	2,845	2,830	1,622	1,949	8	6	2,450	3,100	3,350	3,250	3,600	4,050	2,500	3,000	3,300	3,400	3,850	6,328	6,781	7,194	6,482	6,852	7,306		

Load Capacity

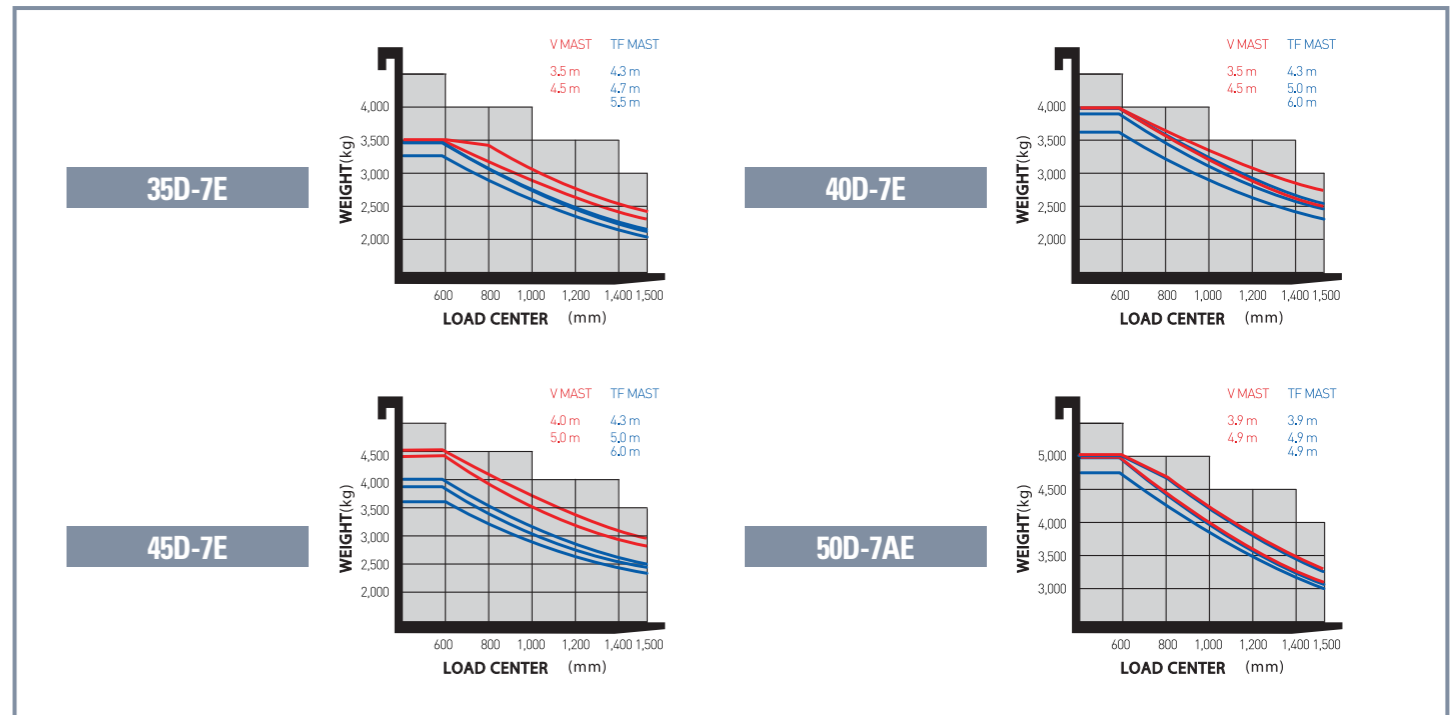

Mast Specification (50D-7AE)

Mast Type	Maximum Fork Height (mm)	Overall Height (Lowered) (mm)		Free Lift Height (mm)		Tilt Angle (deg)		Load Capacity without side shift at 600mm LC (kg)		Load Capacity with side shift at 600mmLC (kg)		Truck Weight (Unloaded) (kg)		
		Single Tire	Double Tire	With Backrest	Without Backrest	Fwd	Bwd	Single Tire	Double Tire	Single Tire	Double Tire	Single Tire	Double Tire	
2 Stage limited free lift	V260	2,630	2,085	2,070	120	120	8	10	5,000	5,000	5,000	5,000	7,151	7,263
	*V290	2,930	2,235	2,220	120	120	8	10	5,000	5,000	5,000	5,000	7,186	7,302
	V320	3,230	2,385	2,370	120	120	8	10	5,000	5,000	5,000	5,000	7,202	7,314
	V340	3,430	2,535	2,520	120	120	8	10	5,000	5,000	4,950	4,950	7,226	7,338
	V360	3,630	2,635	2,620	120	120	8	10	5,000	5,000	4,900	4,900	7,243	7,355
	V390	3,930	2,845	2,830	120	120	8	10	5,000	5,000	4,800	4,800	7,278	7,390
	V440	4,430	3,095	3,080	120	120	8	6	4,900	5,000	4,650	4,650	7,382	7,493
V490	4,930	3,345	3,330	120	120	8	6	4,750	4,850	4,500	4,500	7,424	7,536	
2 Stage full free lift	VF270	2,697	2,135	2,120	905	1,223	8	8	5,000	5,000	4,700	4,750	7,170	7,282
	VF290	2,897	2,235	2,220	1,005	1,323	8	8	4,950	5,000	4,650	4,700	7,195	7,307
	VF305	3,047	2,325	2,310	1,095	1,413	8	8	4,900	4,950	4,550	4,600	7,213	7,325
3 Stage full free lift	TF360	3,672	2,035	2,020	807	1,074	8	8	5,000	5,000	4,700	4,800	7,354	7,458
	TF390	3,972	2,135	2,120	907	1,174	8	8	5,000	5,000	4,650	4,700	7,380	7,484
	TF420	4,272	2,235	2,220	1,007	1,274	8	8	4,850	4,950	4,550	4,650	7,405	7,509
	TF440	4,452	2,295	2,280	1,067	1,334	8	8	4,800	4,900	4,500	4,600	7,421	7,525
	TF460	4,662	2,385	2,370	1,157	1,424	8	8	4,750	4,850	4,450	4,550	7,445	7,549
	TF490	4,962	2,485	2,470	1,257	1,524	8	6	4,650	4,750	4,350	4,450	7,470	7,574
	TF540	5,462	2,665	2,650	1,437	1,704	8	6	4,500	4,650	4,250	4,300	7,522	7,626
TF590	5,972	2,845	2,830	1,617	1,884	8	6	4,400	4,500	4,100	4,200	7,562	7,666	

* Standard

Various Attachments

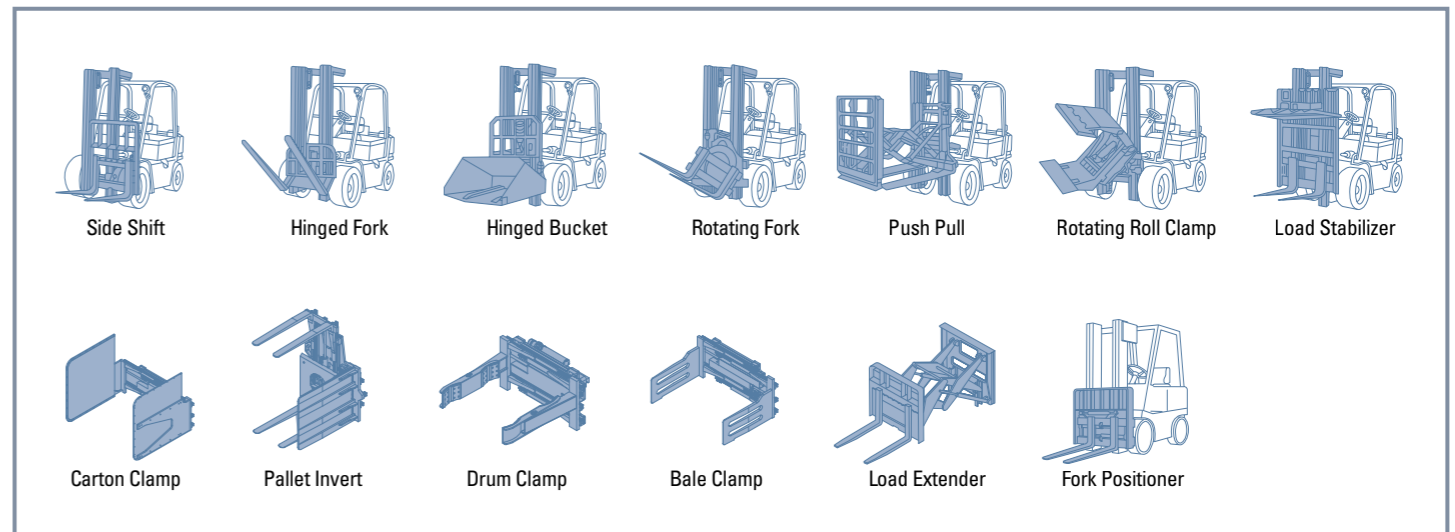

Optional Items

- FORK (LxWxT)(mm)**
 - 35D-7E (HOOK TYPE)**
 - 1,220 X 122 X 50 · 1,370 X 122 X 50 · 1,520 X 122 X 50
 - 1,670 X 122 X 50 · 1,820 X 122 X 50 · 1,970 X 122 X 50
 - 40D-7E (SHAFT · HOOK TYPE)**
 - 1,070 X 150 X 50 · 1,370 X 150 X 50 · 1,520 X 150 X 50
 - 1,670 X 150 X 50 · 1,820 X 150 X 50 · 1,970 X 150 X 50
 - 45D-7E (HOOK TYPE)**
 - 1,220 X 150 X 50 · 1,370 X 150 X 50 · 1,520 X 150 X 50
 - 1,670 X 150 X 50 · 1,820 X 150 X 50 (Class III, IV)
 - 1,970 X 150 X 50 (Class IV)
- 45D-7E (SHAFT TYPE)**
 - 1,220 X 150 X 50 · 1,370 X 150 X 50 · 1,520 X 150 X 50
 - 1,670 X 150 X 50 · 1,820 X 150 X 50 · 1,970 X 150 X 50
- 50D-7AE (HOOK TYPE)**
 - 1,350 X 150 X 60 · 1,500 X 150 X 60 · 1,800 X 150 X 60
 - 2,000 X 150 X 60 · 2,400 X 150 X 60
- MCV** : 3-SPOOL / 4-SPOOL / 5-SPOOL
- SEAT** : ARM REST, HIP REST
- SOLID TIRE**
- OVER SHOE** : 1,600 / 1,800 / 2,000 / 2,200
- HOSE-REEL**
- OVER HEAD GUARD HEIGHT** : 2,500 / 2,340
- CABIN (HEIGHT 2,240)**
- CABIN + HEATER**
- HAZARD SWITCH**
- BEACON LAMP**
- INTEGRAL FORK POSITIONER CARRIAGE (40/45D-7E)**