

Dimension

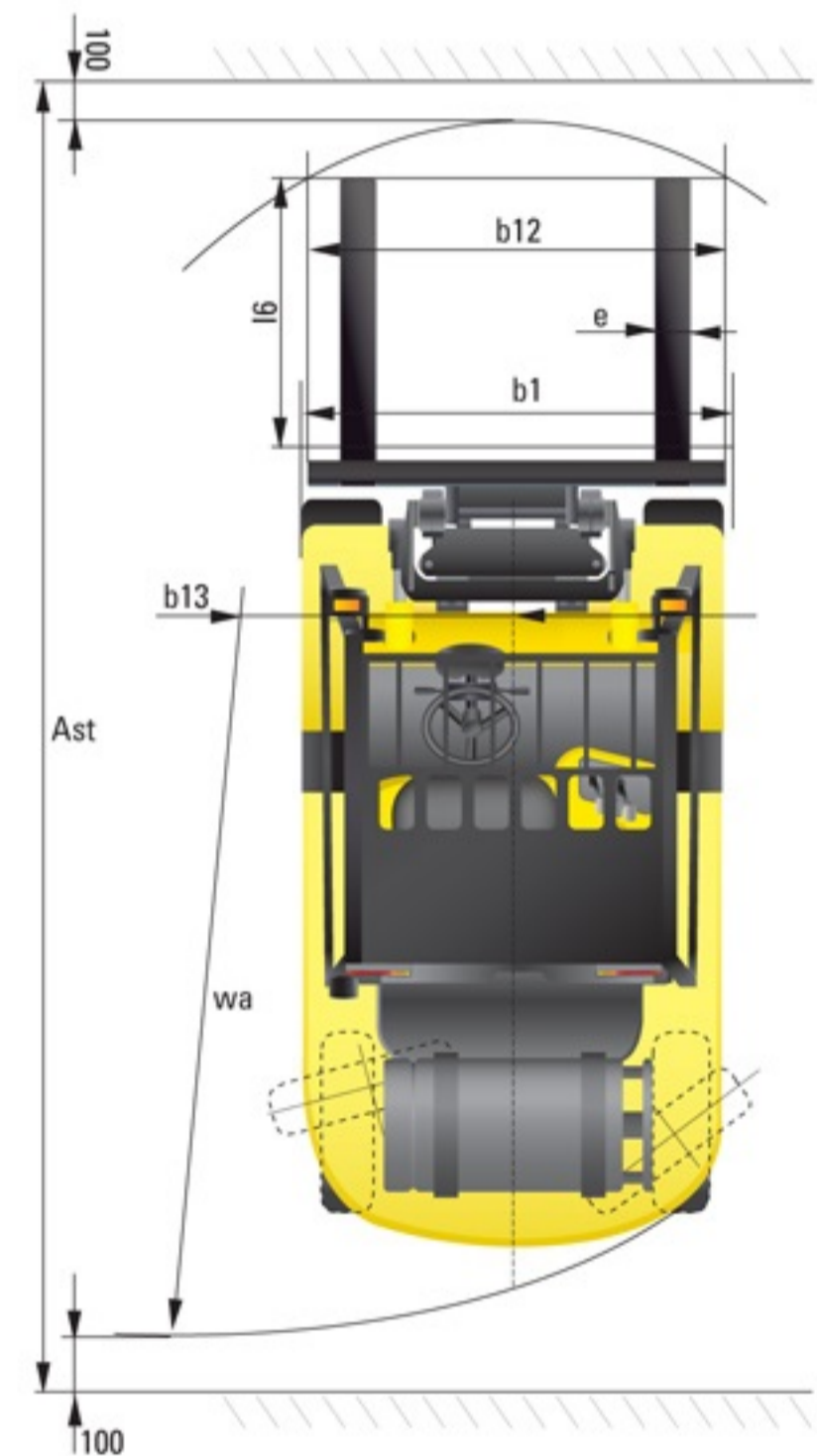

Specification

Identification			
1.1	Manufacturer	Hyundai	Hyundai
1.2	Manufacturer's type designation	15L(G)-7M	18L(G)-7M / 20L(G)-7M
1.3	Drive: electric (battery or mains), diesel, petrol, fuel gas, manual	LP / Gas	LP / Gas
1.4	Type of operation: hand, pedestrian, standing, seated, order-picker	seated	seated
1.5	Load capacity / rated load	Q (kg) 1,500	1,750 / 2,000
1.6	Load center distance	c (mm) 500	500
1.8	Load distance, center of drive axle to fork	x (mm) 393	393 / 398
1.9	Wheelbase	y (mm) 1,410	1,410
2.1	Service weight	kg 2,690	2,861 / 3,045
2.2	Axle loading, loaded front/rear	kg 3,640 / 950	4,006 / 605 / 4,380 / 660
2.3	Axle loading, unloaded front/rear	kg 1,190 / 1,500	1,147 / 1,714 / 1,106 / 1,939
Wheels, Chassis			
3.1	Tires: solid rubber, superplastic, pneumatic, polyurethane	Pneumatic	Pneumatic
3.2	Tires size, front (width x Φ)	6.5 x 10 x 12PR	6.5 x 10 x 12PR
3.3	Tires size, rear (width x Φ)	5.0 x 8 x 10PR	5.0 x 8 x 10PR
3.5	Wheels, number front x rear (x=driven wheels)	2 x 2	2 x 2
3.6	Track width, front	b10 (mm) 890	890
3.7	Track width, rear	b11 (mm) 910	910
Basic Dimensions			
4.1	Mast / fork carriage tilt forward / backward (α / β) degrees	6 / 10	6 / 10
4.2	Lowered mast height	h1 (mm) 2,155	2,155
4.3	Free lift	h2 (mm) 145	150
4.4	Lift height	h3 (mm) 3,325	3,330
4.5	Extended mast height	h4 (mm) 4,332	4,332
4.7	Overhead load guard (cab) height	h5 (mm) 2,110	2,110
4.8	Seat height / standing height	h7 (mm) 1,050	1,050
4.12	Coupling height	h10 (mm) 262	258
4.19	Overall length	l1 (mm) 2,233 + l	2,263 + l / 2,380 + l
4.20	Length to face of forks	l2 (mm) 2,233	2,263 / 2,308
4.21	Overall width	b1 (mm) 1,070	1,070
4.22	Fork dimensions	l / e / s (mm) 900 x 100 x 35	900 x 100 x 35 / 900 x 100 x 40
4.23	Fork carriage ISO 2328, class / type A,B	II / A	II / A
4.24	Fork-carriage width	b12 (mm) 1,004	1,004
4.31	Ground clearance, loaded, under mast	m1 (mm) 120	120
4.32	Ground clearance, centre of wheelbase	m2 (mm) 145	145
4.33	Aisle width for pallets 1000x1200 crossways	Ast (mm) 3,594	3,620 / 3,661
4.34	Aisle width for pallets 800x1200 lengthways	Ast (mm) 3,794	3,820 / 3,861
4.35	Turning radius	Wa (mm) 2,000	2,026 / 2,061
4.36	Smallest pivot point distance	b13 (mm) 589	589
Performance Data			
5.1	Travel speed, Unloaded	km/h 20.1	20.1
5.2	Lift speed, Loaded/Unloaded	mm/s 650 / 680	650 / 680
5.3	Lowering speed, Loaded/Unloaded	mm/s 500 / 450	500 / 450
5.5	Drawbar pull, Loaded	kg 1,736	1,746 / 1,760
5.7	Gradient performance, Loaded	% 39.7	35.4 / 33.0
5.10	Service brake	Hydraulic	Hydraulic
Engine			
6.1	Engine manufacturer / type	L4KB	L4KB
6.2	Engine power acc. to ISO 1585	HP 50	50
6.3	Rated speed	1/min 2,450	2,450
6.4	No. of cylinder / cubic capacity	/cm ³ 4 / 2,359	4 / 2,359
Other Details			
8.2	Type of drive control	Power Shift	Power Shift
8.3	Operating pressure	bar 225 / 168	225 / 168
8.4	Oil volume	l/min 30	30
8.5	Noise	db(A) 80	80

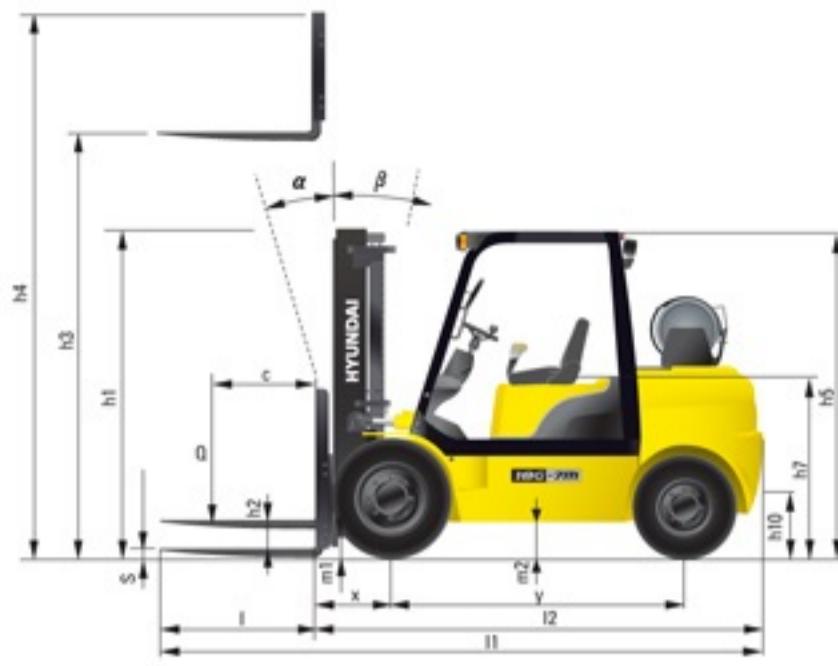

Some of the photos may include optional equipment.

HYUNDAI LPG FORKLIFT TRUCKS **Applied Tier 4 Engine**

15/18/20L(G)-7M

HYUNDAI
HEAVY INDUSTRIES CO.,LTD.

ООО "ЮЖУРАЛПОГРУЗЧИК"
454085, РФ, г. Челябинск, ул. Танкистов, 179 корпус Б
Тел/факс: 8-351- 270-20-55, 755-52-70
2702055@mail.ru

www.urforklift.ru

HYUNDAI
HEAVY INDUSTRIES CO.,LTD.

We build a better future

NEW criteria of Forklift Trucks

Hyundai introduces a new line of 7M series LPG forklift trucks. Excellent power and performance make your business more profitable.



OPSS (Operator Presence Sensing System)

Control of mast tilting, lifting and lowering is not possible through operation of the appropriate control when the not in the seated position.

The new master on the job-site!

Smooth running, efficient and ergonomically designed, 15/18/20L(G)-7M series are made to meet your needs.

50PS/2,450rpm

Powerful Engine L4KB Engine

Market approved quality of L4KB engine ensures incomparable performance, durability and additional value to the machine. Powerful and efficient engine provides excellent fuel economy and excellent torque for improved operation.(EPA/CARB Tier-IV Certified)

Fast and Stable Performance

Being able to quickly raise and lower the mast, as well as tilt it forward and backward, provides the best operational conditions during unloading.

When the truck is fully loaded, mast lowering speed is carefully controlled to ensure safety by the down control valve.

Mast, Lift and Tilt Lock System is standard.



**High Power
Low Noise**

Some of the photos may include optional equipment.

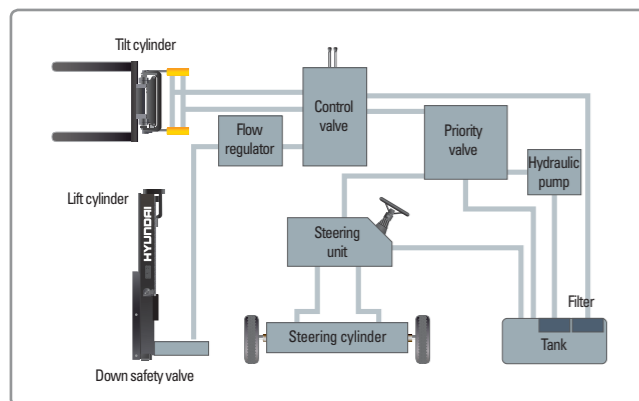

State-of-the-art Hydraulic System

The latest large-capacity hydraulic system reacts quickly during operation, and a low-noise control valve increases both efficiency and durability.



Fully Hydrostatic Power Steering

A hydraulic steering system always guarantees smooth and flexible steering, preventing overrun and kick-back.



Increased Mast Tilting Angle

Utilizing the mast tilting angle of 6 degrees forward and 10 degrees backward, the operator can safely and rapidly perform loading and unloading jobs.

Faster Travel Speed & Better Gradability

The powerful high-output engine provides greater acceleration, better gradability and faster travel speed on any tough terrains or slopes.



Gradability(Loaded)

- 15L(G)-7M : 39.7°
- 18L(G)-7M : 35.4°
- 20L(G)-7M : 33.0°

Travel Speed(Unloaded)

- 15L(G)-7M : 20.1 km/h
- 18L(G)-7M : 20.1 km/h
- 20L(G)-7M : 20.1 km/h

Ergonomic operator friendly compartment design!

A design based on human engineering relieves fatigue and increases operator's efficiency.

Operator Friendly Gauges and Water-resistant Monitor Panel

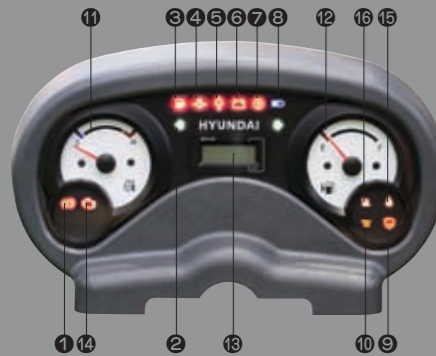

- 1 Parking brake lamp
- 2 Directional indicators
- 3 Fuel warning lamp
- 4 Engine oil warning lamp
- 5 Transmission oil temperature warning lamp
- 6 Battery charging warning lamp
- 7 Air cleaner filter warning light
- 8 Working light indicator
- 9 Water separator lamp
- 10 Pre-heater indicator
- 11 Water temperature gauge
- 12 Fuel gauge
- 13 Hour meter
- 14 Engine check lamp
- 15 Seat belt warning
- 16 OPS warning



- Grammer Seat (Option)**
- Quick Achievement of the Ergonomically Best Sitting Position
 - Asymmetrical Backrest
 - Movable Armrests - Seat Heating
 - Practical Document Box



New High Visibility for Safe Operation
The operator is able to work with increased safety and accuracy due to a wider view mast.



Travel Speed Control System (Option)

- In-Door : Max. Travel Speed 15~17 km/h
- Out Door : Max Travel Speed : Max. Vehicle Speed

Some of the photos may include optional equipment.



Ergonomically Positioned Pedals
Based on human engineering, the accelerator, brake and inching pedals are optimally positioned for convenience while operating the equipment.



Cup Holder & Console Box
Additional storage spaces are located inside the operating space for operator's convenience.



Quick Response of Operating Control Levers
Only minimal operator's effort is required for precise, safe and productive control.



Adjustable Steering Wheel
Steering wheel with horn button can be adjusted by a lever on the right-hand side for the most comfortable operator position.



Easy and Safe Shift Lever
A single lever on the left side of the steering column gives the operator fast, easy control of direction. The lever must be in the neutral position before the engine can be started.



Secondary Horn
Secondary Horn gives access to lights and horn

Danger-free through high durability!

Safety and durability are priorities in design of the equipment.



Strong Overhead Guard

The safety overhead guard meets ISO 6055 regulation and protects the operator during hazardous jobs.



Parking Brake

Ratchet type parking brake requires less effort from the operator to set.

Highly Durable Split type Drive Axle

The bevel gear set and hub reduction drive axle smoothly delivers desired torque to the drive wheels.



Some of the photos may include optional equipment.



Large Footboard & Hand Grip

Wide "open" step offers convenience and safety when entering and exiting truck.



Expansion Bellows

The expansion bellows absorbs vibration and reduces noise generated from the exhaust system and also extends the life cycle of exhaust system.



Electrically Monitored Air Filter

Air cleaner sensor alerts the operator of a restricted air filter and allows replacement before damage.

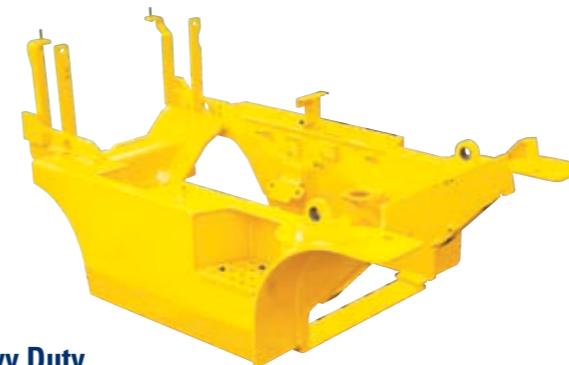

Heavy Duty Single Unit Frame

Heavy duty single unit type frame, designed on the basis of accurate structural analysis, guarantees durability and safety.



Bright, Protected Headlights

Bright, Protected head lights are positioned for exceptional visibility.



Rear Safety Lamp

Rear combination lamps with directional indicators, rear lights and brake lights are positioned for a high level of safety.

Designed for quick and easy service!

An ideal arrangement of component parts ensures easy access and convenience for maintenance.



Easy Change Air Cleaner

The air filter is readily accessible for cleaning or replacement. (6inch Cyclone Type)



Fast Service Access for Daily Fluids Check



Rotational Battery Installation



One Touch, No Tool Floor Plate



Aluminum Radiator with Superb Protection Against heat



Improvement in Maintenance of Electric Parts

Various electric parts are centralized in dash board resulting in effortless troubleshooting.



Easy Maintenance Oil Check

The T/M oil level can be checked easily without any disassembly.

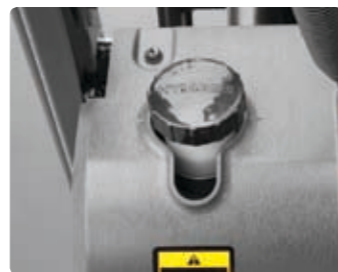

Brake Fluid Reservoir

Highly visible, easily accessible reservoir makes for quicker daily inspections.



An Accessible, Compact Fuse Box for Easy Inspection

Mast Specification

Mast Type	Maximum Fork Height (mm)	Overall Height Lowered (mm)	Tilt Angle (deg)		Free Lift (in)				Load Capacity w/o Integral Side Shift 500mm (kg)			Load Capacity w/Integral Side Shift 500mm (kg)			Truck Weight Unload			
			Fwd	Bwd	With Backrest		With / o Backrest		Single Tire			Single Tire			Single Tire			
					15L/18L(G)-7M	20L(G)-7M	15L/18L(G)-7M	20L(G)-7M	15L(G)-7M	18L(G)-7M	20L(G)-7M	15L(G)-7M	18L(G)-7M	20L(G)-7M	15L(G)-7M	18L(G)-7M	20L(G)-7M	
2-Stage Limited Free Lift	V250	2,525	1,755	6	10	145	150	145	150	1,500	1,750	2,000	1,400	1,650	1,890	2,764	2,938	3,085
	V270	2,725	1,855	6	10	145	150	145	150	1,500	1,750	2,000	1,400	1,650	1,890	2,778	2,952	3,099
	V300	3,025	2,005	6	10	145	150	145	150	1,500	1,750	2,000	1,400	1,650	1,890	2,798	2,972	3,119
	*V330	3,325	2,155	6	10	145	150	145	150	1,500	1,750	2,000	1,400	1,650	1,890	2,818	2,992	3,139
	V350	3,525	2,255	6	10	145	150	145	150	1,500	1,750	2,000	1,400	1,650	1,890	2,832	3,006	3,152
	V370	3,725	2,355	6	10	145	150	145	150	1,500	1,750	1,950	1,400	1,650	1,845	2,845	3,019	3,166
	V400	4,025	2,505	6	10	145	150	145	150	1,450	1,735	1,950	1,365	1,635	1,465	2,870	3,044	3,190
	V450	4,525	2,855	6	6	145	150	145	150	1,375	1,650	1,500	1,290	1,550	1,420	2,936	3,110	3,257
3-Stage Full Free Lift	V500	5,025	3,105	6	6	145	150	145	150	1,300	1,450	1,000	1,225	1,365	940	2,970	3,144	3,290
	V550	5,525	3,355	6	5	145	150	145	150	1,000	950	750	930	880	690	2,990	3,164	3,311
	TF/TS370	3,735	1,805	6	6	798	803	1,299	1,300	1,500	1,750	1,925	1,400	1,650	1,820	2,913	3,087	3,243
	TF/TS400	4,035	1,905	6	6	898	903	1,399	1,400	1,500	1,700	1,875	1,400	1,600	1,775	2,933	3,107	3,263
	TF/TS430	4,335	2,005	6	6	998	1,003	1,499	1,500	1,450	1,700	1,825	1,365	1,600	1,725	2,952	3,126	3,282
	TF/TS450	4,535	2,105	6	6	1,098	1,103	1,599	1,600	1,425	1,635	1,650	1,340	1,540	1,550	2,971	3,145	3,301
	TF/TS470	4,735	2,155	6	6	1,148	1,153	1,649	1,650	1,400	1,450	1,350	1,320	1,365	1,275	2,938	3,157	3,313
	TF/TS500	5,035	2,255	6	6	1,248	1,253	1,749	1,750	1,375	1,400	1,000	1,295	1,320	935	3,002	3,176	3,332
	TF/TS550	5,535	2,455	6	5	1,448	1,453	1,949	1,950	1,050	1,100	750	985	1,030	690	3,040	3,214	3,370
	TF/TS600	6,035	2,655	6	5	1,648	1,653	2,149	2,150	750	750	500	700	700	450	3,112	3,286	3,442
TF/TS650	6,535	2,855	3	3	1,848	1,853	2,349	2,350	500	500	450	450	450	400	3,157	3,331	3,487	
TF/TS700	7,035	3,055	3	3	2,048	2,053	2,549	2,550	350	250	300	300	200	250	3,193	3,367	3,523	

* TS-Mast : Wide Visible 3 Stage Full Free Lift Mast with 2 Free Lift Cylinders.

* Standard

Load Capacity

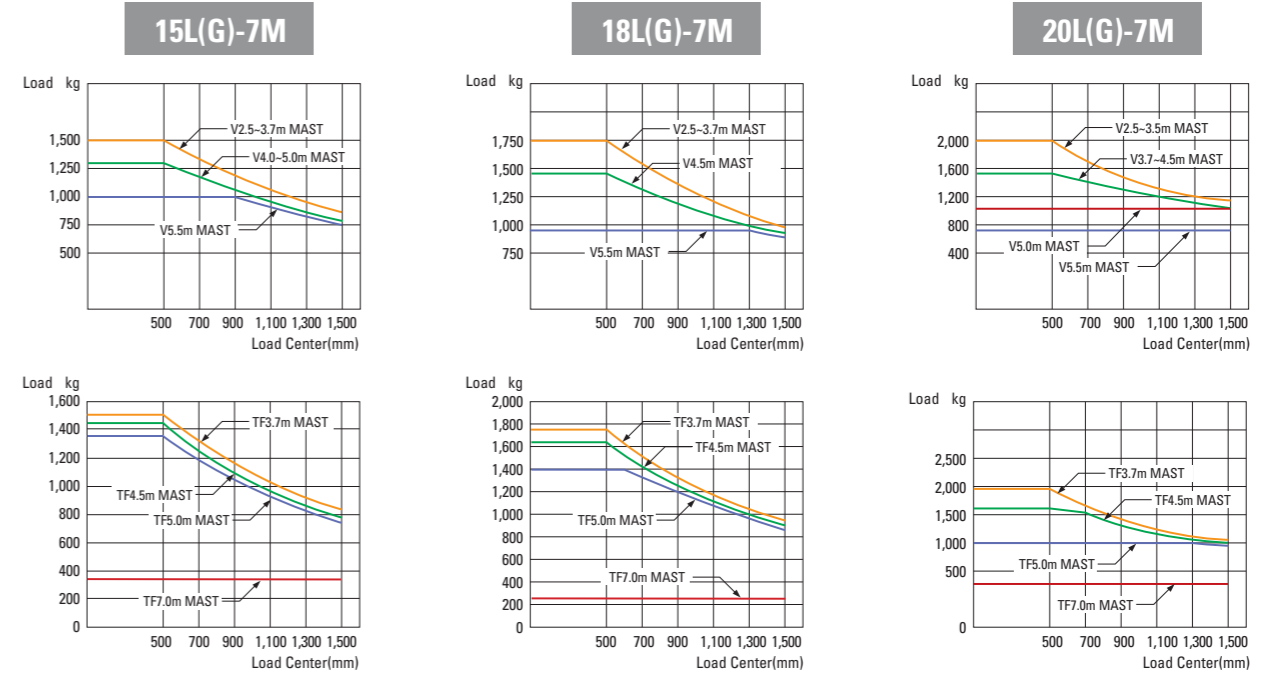

Optional Items

- **SIDE SHIFT**
- **INTEGRAL SIDE SHIFT**
- **FORK** : 750 / 850 / 1,050 / 1,200 / 1,350 / 1,500 mm [15/18L(G)-7M]
950 / 1,000 / 1,050 / 1,150 / 1,200 / 1,350 / 1,500 / 1,600mm [20L(G)-7M]
- **OVER SHOE** : 1,300 / 1,500 / 1,700mm
- **TILTING** : 6/5°, 3/3°, 6/6°
- **TIRE** : Cushion, No-marking
- **SEAT** : Pocket, Arm Rest, Hip Rest
- **LPG CLAMP** : Swing Out, Swing Down
- **M.C.V** : 4-Spool
- **ATTACH PIPING** : 3 Spool-piping, 4 Spool-piping
- **MASTER SWITCH**
- **BEACON LAMP**
- **HAZARD SWITCH**
- **WORK LAMP**
- **SPEED CONTROL SENSOR**