

Power Reach Stacker

Ричтраки. (Самоходные штабелеры с горизонтальным выдвижением мачты)

Tisel Technics

PRS



1300

4500

TISEL Technics,

PRS13,

24-

3

HYDRAPP

3.3 kW

TISEL PRS

30

1300

4500

3700 4500

Sauer-Danfoss ()
 Curtis
 HYDRAPP ()
 : METALROTA,
 CURTIS ()

Power Reach Stacker

Ричтраки (Самоходные штабелеры с горизонтальным выдвижением мачты)

TISEL PRS13

H3+H13	(Q)	
2500	1300	700
3000	1000	600
3700	900	500
4500	800	400
()	600	700

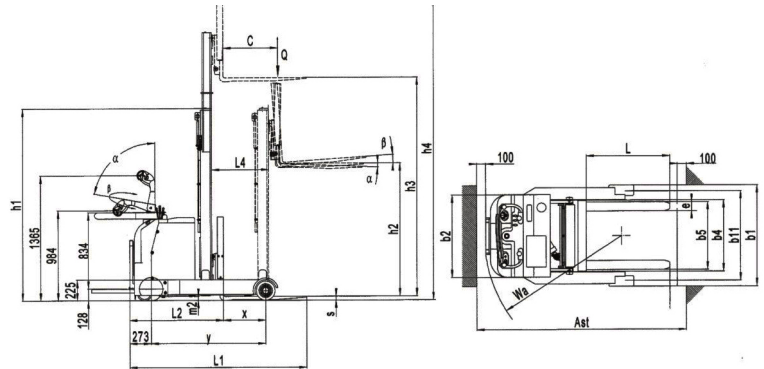

TISEL PRS13

		PRS1316	PRS1318	PRS1330	PRS1337	PRS1345
	Q	1300	1300	1300	1300	1300
	X	388	388	388	418	418
	Y	1255	1255	1255	1355	1355
	/	1480/1640	1500/1650	1580/1740	1680/1855	1770/1990
	/	1350/470	1370/480	1495/525	1655/580	1820/640
	()	230x75	230x75	230x75	230x75	230x75
	/	210x85	210x85	210x85	210x85	210x85
	/	150x54	150x54	150x54	150x54	150x54
	: - / (-)	1 + 2/2	1 + 2/2	1 + 2/2	1 + 2/2	1 + 2/2
	b10	620	620	620	620	620
	b11	993	993	993	993	993
	h1	2075	2275	2095	1850	2075
	h2	-	-	221	1205	1490
	h3	1560	1760	2960	3660	4460
	h4	2145	2345	3940	4625	5430
	min/max	h14	984/1365	984/1365	984/1365	984/1365
		h13	40	40	40	40
	/	h3+h13	1600	1800	3000	3700
	/	/	2/4	2/4	2/4	2/4
	i4	550	550	550	580	580
	i1	2025	2025	2025	2125	2125
	i2	867	867	867	937	937
	b1	1104	1104	1104	1104	1104
	s/e/l	35/100/1150	35/100/1150	35/100/1150	35/100/1150	35/100/1150
	b5	200-720	200-720	200-720	200-720	200-720
	G	59	59	59	59	59
	1000 1200	Ast	2307	2307	2436	2436
	800 1200	Ast	2355	2355	2478	2478
		Wa	1450	1450	1600	1600
	/	/	5.4/6.0	5.4/6.0	5.4/6.0	6.0/7.0
	/	/	85/122	85/122	85/122	110/165
	/	/	125/80	125/80	125/80	300/220
	%	5/8	5/8	5/8	5/8	5/8
	kw	1.5	1.5	1.5	1.5	1.5
	kw	2.2	2.2	2.2	3.0	3.0
	-	3PzS	3PzS	3PzS	5PzS	5PzS
		24/270	24/270	24/270	24/400	24/400
	T	MOSFET	MOSFET	MOSFET	MOSFET	MOSFET
		1820	1850	2020	2235	2460
	dB	67	67	67	67	67